



BY APPOINTMENT TO
HER MAJESTY QUEEN ELIZABETH II
MANUFACTURERS OF DAIMLER AND JAGUAR CARS
JAGUAR CARS LIMITED COVENTRY



BY APPOINTMENT TO
HER MAJESTY QUEEN ELIZABETH
THE QUEEN MOTHER
MANUFACTURERS OF DAIMLER AND JAGUAR CARS
JAGUAR CARS LIMITED COVENTRY



BY APPOINTMENT TO
HIS ROYAL HIGHNESS THE PRINCE OF WALES
MANUFACTURERS OF DAIMLER AND JAGUAR CARS
JAGUAR CARS LIMITED COVENTRY



JAGUAR

POWERTRAIN Automatic Transmissions Service Manual

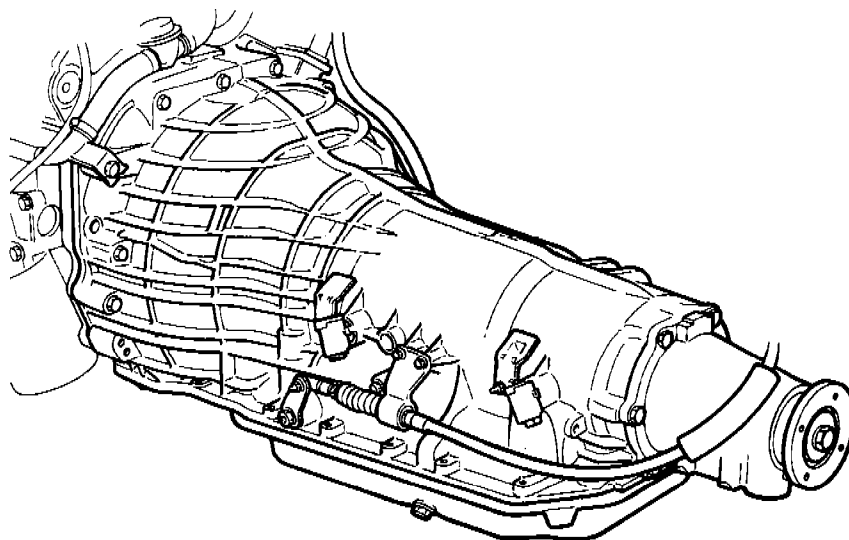

Published by Product Development & Publications
Jaguar Cars Limited

Part of set – JJM 10 04 12 / 50



CONTENTS

Section	Title	SRO	Page
	Foreword		ii
I	Service Tools & Equipment		iii
II	Torque Tightening Specifications		iii
III	Service Materials		iii
IV	Service Data		iii
1.1	General Description		1
1.1.1	Gear Range		1
1.1.2	Lubrication Circuits		3
1.1.3	Cooler Circuit		3
1.2	Transmission Components		5
1.2.1	Torque Converter		5
1.2.2	Planetary Gear Sets		5
1.2.3	Torque Converter Clutch		5
1.2.4	Pulse Width Modulated (PWM) Solenoid		6
1.2.5	Input And Output Speed Sensors (TISS) And (TOSS)		6
1.2.6	Shift Solenoids 'A' And 'B'		6
1.2.7	Variable Force Solenoid / Motor (VFS)		6
1.2.8	Transmission Control Module (TCM)		6
1.2.9	Pressure Switch Manifold (PSM)		6
1.2.10	Transmission Temperature Sensor		6
1.2.11	Accumulators		6
1.3	Oil Pump And Internal Valves		7
1.3.1	Pressure Regulator Valve Train		7
1.3.2	Reverse Boost Valve		7
1.3.3	Torque Converter Clutch Enable Valve		7
1.3.4	Torque Converter Clutch Shift Valve		7
1.3.5	Converter Limiting Valve		7
1.4	Valves In Valve Body		8
1.4.1	Torque Signal Compensatory Valve		8
1.4.2	Checkball Valves		8
1.4.3	Active Components For Each Gear Ratio		10
1.5	Hydraulic Circuit Diagrams		11
1.6	Fault Diagnosis		24
1.6.1	Initial Checks		24
1.6.2	Engine Tune		24
1.6.3	Stall Test		24
1.6.4	Road Test		24
1.6.5	Electrical Checks		24
1.6.6	Transmission Fault Codes		25
1.7	Service Operations		26
1.7.1	Rear Servo Assembly – Renew (6.0L)	44.34.13	26
1.7.2	Front Servo Assembly – Renew (4.0 liter SC and V12)	44.34.17	27
1.7.3	Valve Body And Accumulator – Remove For Access and Refit (4.0 liter SC and V12)	44.40.05 / 90	28
1.7.4	Valve Body Assembly – Renew (4.0 liter SC and V12)	44.40.06	29



FOREWORD

This manual provides information relevant to the servicing of Automatic Transmission Units 4L80-E (irrespective of the vehicle range to which the unit is fitted). The manual should be used in conjunction with the relevant Vehicle Service Manual (VSM) and Electrical Diagnostic Manual (EDM).

It assumes that the transmission has been removed from the vehicle, in accordance with the Vehicle Service Manual, and is in a clean condition and all service tools and materials are available.

The manual is divided into sections covering:

- Sub-section 0 – service information
- Sub-section 1 – detailed mechanical description
- Sub-section 2 – general data (service-relevant)
- Sub-section 3 – hydraulic circuit diagrams
- Sub-section 4 – troubleshooting
- Sub-section 5 – service repair operations.

An index can be found at the rear of the manual.

Note: For information relating to in-vehicle operations, refer to the Vehicle Service Manual.

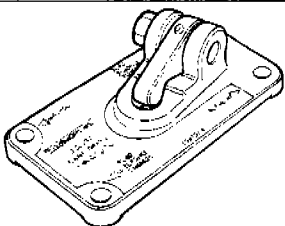
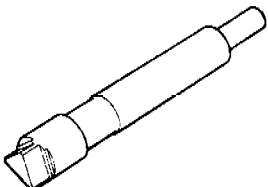

I. SERVICE TOOLS & EQUIPMENT

Illustration	Jaguar Number	Description	Notes
	JD 192	Pin checking tool	
	JD 193	Stepped gauge pin	

II. TORQUE TIGHTENING SPECIFICATIONS

Fixing	Tightening Torque (Nm)
Nut on checking tool JD 192	34

III. SERVICE MATERIALS

Description	Uses	Notes
To be issued		

IV. SERVICE DATA

Item	Description	Data
Explanation of model designation 4L80-E		4 = 4 Speed
		L = Longitudinal mounting
		80 = Series (based on relative torque capacity)
		E = Electronic control
Gear ratios	1st	2,482 : 1
	2nd	1,482 : 1
	3rd	1,000 : 1
	4th	0,750 : 1
	Reverse	2,077 : 1
Engine torque	Maximum torque (into the converter)	597 Nm
Gearbox torque	Maximum torque (at the turbine shaft)	1200 Nm
Maximum shift speed (all upshifts)	4 liter s / c	5500 RPM
	6.0 liter	6000 RPM
Torque converter	Diameter	310 mm
	Stall torque ratio	2,6 : 1
Transmission fluid capacity	Drain and refill only	7,3 liter
	Complete fill	12,8 liter
Transmission fluid	Top-up	Dexron 3
	Fill	Dexron 3
Transmission weight	Empty	105 kg
	Complete with fluid	117 kg



1.1 GENERAL DESCRIPTION

This manual provides information relating to the 'Powertrain' (formerly Hydra-Matic) 4L80-E automatic transmissions fitted to the X-300 vehicle range.

The Powertrain 4L80-E is a four-speed, high torque capacity, electronically controlled automatic transmission, which comprises a torque converter with lock-up direct drive clutch and three planetary gear sets. Five multiple disc clutches, one intermediate sprag clutch assembly, two roller clutch assemblies and two band assemblies provide the drive elements necessary for correct sequential gear engagement and operation.

The torque converter containing a pump, turbine (rotor), a stator assembly, and a clutch pressure plate splined to the turbine, acts as a fluid coupling for smooth torque transmission from the engine. The converter also supplies additional torque multiplication when necessary, and the torque converter clutch (TCC) pressure plate provides a mechanical direct drive or 'lock-up' above a certain speed in top gear for greater fuel economy.

Gear shift operations are controlled from the Transmission Control Module (TCM), which governs the electronically controlled valve body situated within the transmission.

Three planetary gear sets provide reverse and the four forward ratios, the changing of which is fully automatic in relation to load, vehicle speed and throttle opening. The transmission control module (TCM) receives and integrates various vehicle sensor input signals, and transmits operating signals to the solenoids located in the control valve assembly. These solenoids govern the transmission operating pressures, up-shift and down-shift gear selection patterns, and also the torque converter clutch operation from a pulse width modulated solenoid control.

The performance mode switch provides for selection of 'sport' or 'normal' mode as required by the driver. The switch input to TCM changes the gear shift pattern such that in 'sport' mode, shifts take place at higher engine speeds.

The 'kick-down' facility is activated by full downward travel of the accelerator pedal, providing a signal to TCM requesting greater acceleration hence downward gear shifts.

1.1.1 Gear Ranges

Selectable gear positions are: P – Park, R – Reverse, N – Neutral, D – Drive, 3, 2. The selected gear is displayed on a gear selection illumination module located above the selector mechanism.

P – Park position of the selector lever provides a mechanical locking of the output shaft of the transmission, and as such, must only be engaged when the vehicle is stationary. In addition, and for extra safety, the handbrake should also be applied. It is necessary to have the ignition on and the footbrake applied to move the selector lever from the Park position. For ignition key removal the selector lever must be in the Park position. The engine can be started in the Park position.

R – Reverse enables the vehicle to be operated in a rearwards direction. The engine cannot be started in the Reverse position.

N – Neutral position enables the engine to be started and operated without driving the vehicle. It also allows the vehicle to be moved manually for access, ie. for removal of the propeller shaft.

D – Drive position allows the automatic selection of all four forward gear ratios during normal driving conditions for maximum efficiency and fuel economy. On acceleration, down-shifts are obtained by depressing the accelerator pedal or by manual selection. The engine cannot be started in this position.

3 – Manual third position allows automatic operation of the three lower gear ratios but inhibits selection of the fourth ratio. This position is used for towing a trailer or negotiating hilly terrain when greater engine braking control is required. The engine cannot be started in this position.

2 – Manual second position allows automatic operation of the two lower gear ratios but inhibits selection of the third and fourth ratios. This position is used for heavy traffic congestion or negotiating hilly terrain when even greater engine braking control is required than is provided by manual third. This ratio may be selected at any vehicle speed – even if the transmission is in third or fourth ratio, the transmission will immediately down-shift to second gear provided the vehicle speed is below 137 km/h (85 mile/h). The engine cannot be started in this position.

Note: With the performance mode switch in the 'normal' position, the vehicle will pull away in second gear. However, if more than 75 per cent of throttle is applied when the vehicle speed is between zero and 13 km/h (8 mile/h), then first gear will be selected. From 13 to 61 km/h (8 to 38 mile/h) first gear is obtainable by 'kick-down'. In 'sport' mode the vehicle pulls away in first gear and the transmission operates fully in all four forward gears.

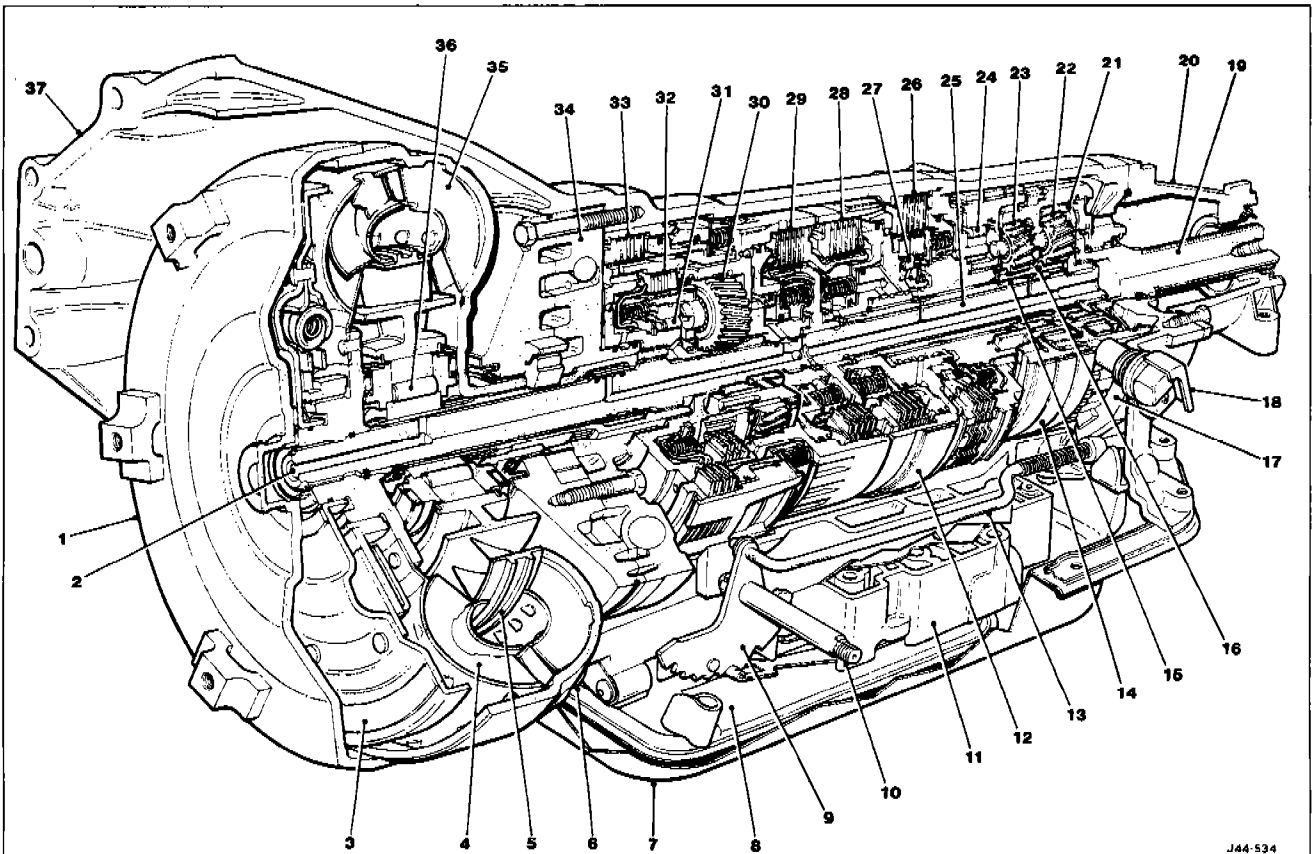

J44-534

- | | | |
|----------------------------------|-------------------------------------|--------------------------------------|
| 1. Torque converter | 14. Rear band | 27. Intermediate sprag clutch |
| 2. Turbine shaft | 15. Sun gear shaft | 28. Direct clutch |
| 3. Pressure plate | 16. Sun gear | 29. Forward clutch |
| 4. Converter turbine | 17. Parking lock pawl | 30. Overdrive planetary carrier assy |
| 5. Converter stator | 18. Transmission case | 31. Overdrive roller clutch |
| 6. Variable force motor solenoid | 19. Output shaft | 32. Overrun clutch |
| 7. Sump pan | 20. Rear extension housing | 33. Fourth clutch |
| 8. Filter | 21. Rear internal gear | 34. Pump assy |
| 9. Interior detent lever | 22. Output planetary carrier assy | 35. Converter pump |
| 10. Manual shaft | 23. Reaction planetary carrier assy | 36. Stator roller clutch |
| 11. Control valve | 24. 'LO' roller clutch | 37. Output speed sensor |
| 12. Front band | 25. Main shaft | |
| 13. Parking lock actuator | 26. Intermediate clutch | |

Fig. 1 Powertrain 4L80-E Transmission assembly

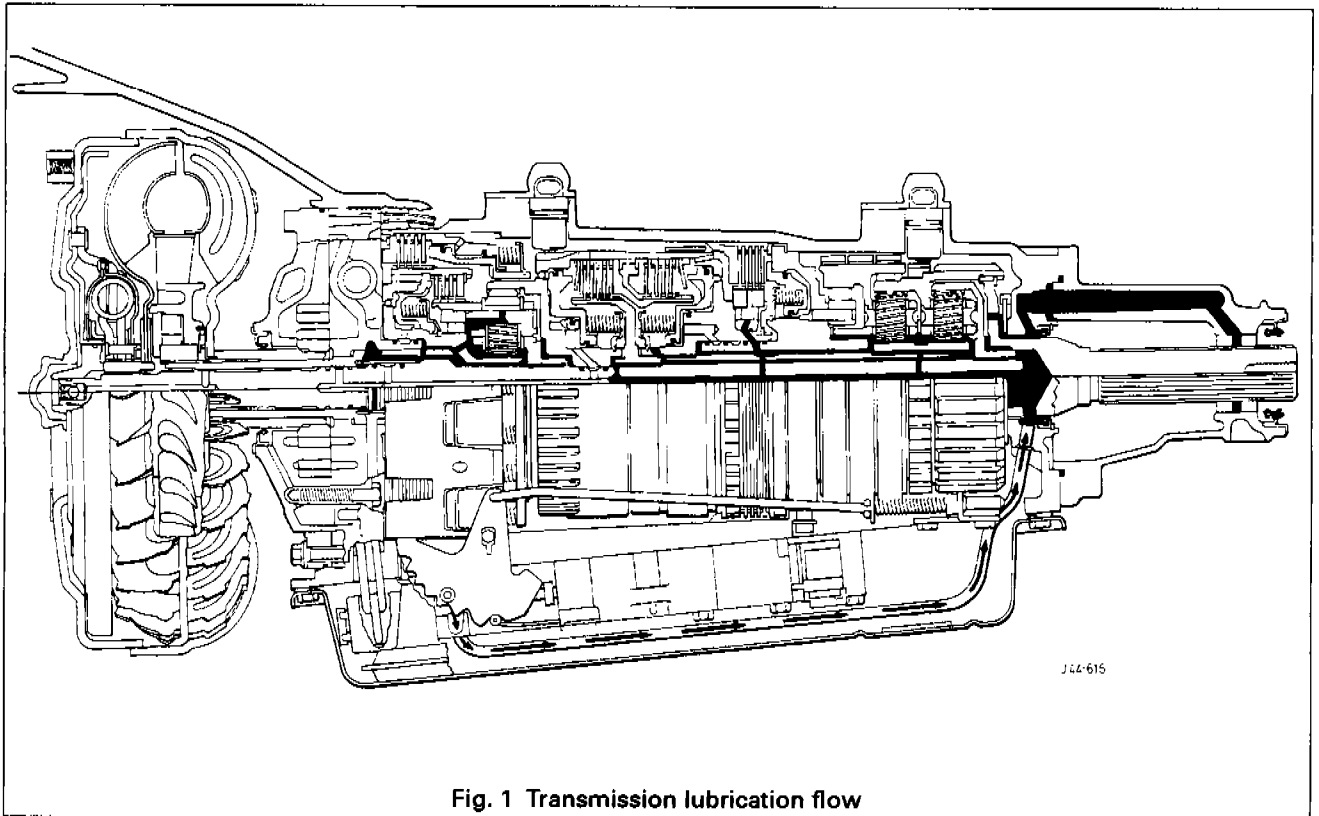

Fig. 1 Transmission lubrication flow

1.1.2 Lubrication Circuits

Transmission oil passes from the transmission unit, through the oil cooler and returns to the transmission unit via a connector in the case, into the valve body and into the lubrication pipe. The fluid is then routed to the rear of the transmission to lubricate the rear case, the rear extension housing bearing and the rear gearsets.

Lubrication fluid is also routed through the pump assembly and into the overrun clutch housing where it passes to the various apply components to cool and lubricate the transmission clutches and gear sets.

1.1.3 Cooler Circuit

With the torque converter clutch (TCC) released, transmission fluid returning from the torque converter is fed through the TCC shift valve into the cooler circuit, ie through the cooler feed pipe to the transmission cooler in the radiator and then back to the transmission unit lubrication circuits.

When the TCC is applied, ie the shift valve in the apply position, regulator converter fluid is passed through the valve and into the cooler circuit as described above.

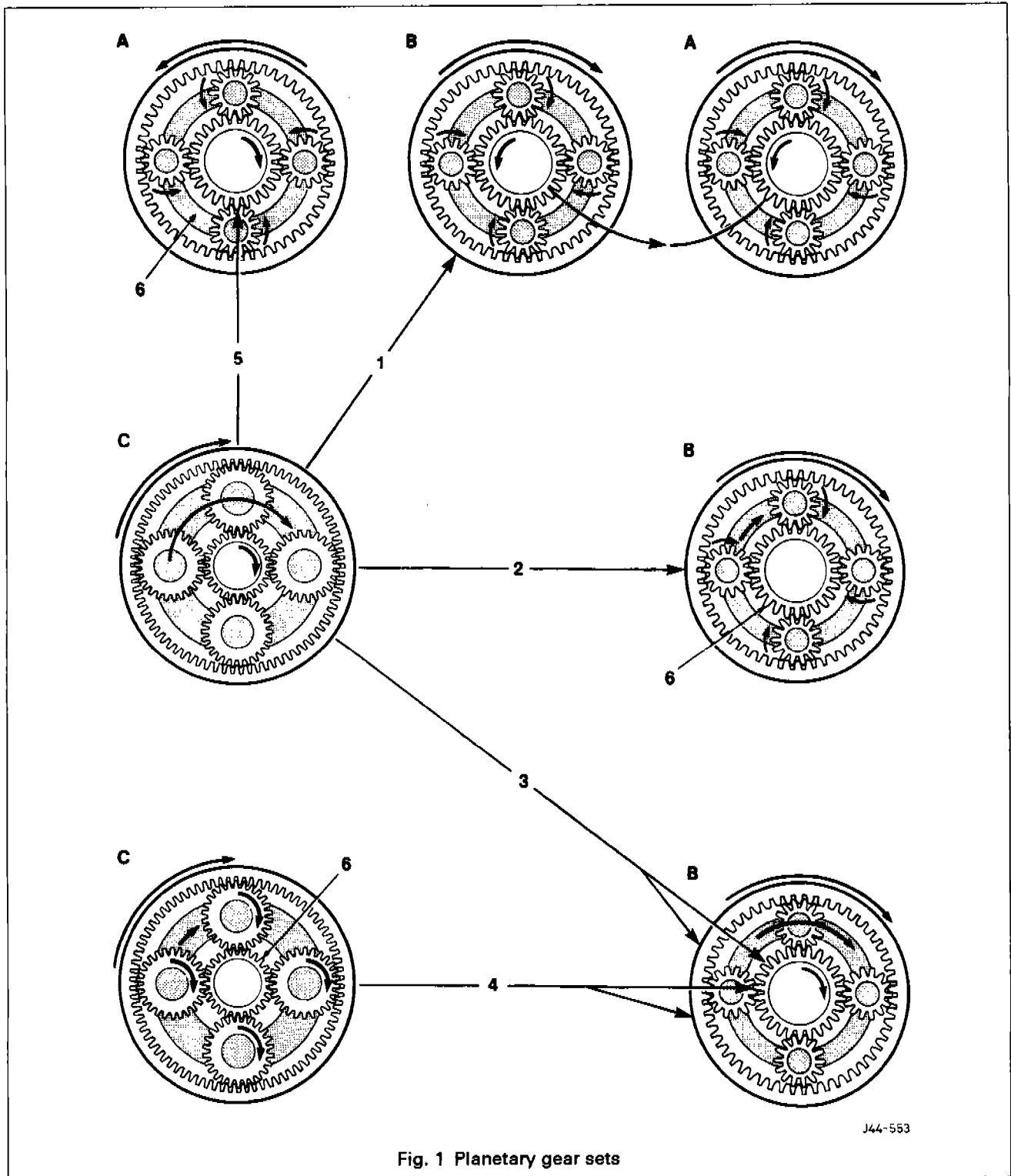

J44-553

Fig. 1 Planetary gear sets



1.2 TRANSMISSION COMPONENTS

1.2.1 Torque Converter

The torque converter is a three element (single stator) unit which acts as a fluid coupling to connect the engine power smoothly to the transmission gear train, and as a torque multiplier to provide extra power when pulling away from rest. The three elements of the converter are the pump (impeller), the turbine and the stator.

1.2.2 Planetary Gear Sets

Three planetary gear sets are used in this transmission: 'overdrive', 'reaction' and 'output'.

Each gear set comprises a center or sun gear, an annulus or internal gear, and a planetary carrier assembly which contains the smaller planet gears.

Direct drive in a planetary gear set is obtained when any two parts of a gear set rotate in the same direction at the same speed, thus driving the third component at the same speed. The planetary gears in this case act as wedges to drive the entire gear set as one unit and therefore the output speed of the transmission is the same as the input speed from the torque converter.

Conversely, a planetary gear set reverses the direction of power flow when a carrier assembly is held stationary and power is applied to the sun gear thus causing the planetary gears to act as idler gears to drive the internal gear in the opposite direction.

In first, second and third gears, the 'overdrive' roller clutch retains the 'overdrive' sun gear and carrier assembly together, thereby driving the internal gear at the same speed.

In first gear, the 'output' internal gear drives the 'output' carrier planet gears clockwise, which causes the sun gear to rotate anti-clockwise. As the 'output' sun gear and the 'reaction' sun gear are common, the 'reaction' carrier planet gears rotate clockwise. The 'reaction' carrier, being held stationary by the 'LO' roller clutch, then causes the 'reaction' carrier planet gears to drive the 'reaction' internal gear and the output shaft, ie first gear.

Second gear is obtained when the 'output' / 'reaction' sun gear is held stationary by the intermediate clutch and therefore when the 'output' carrier planet gears are driven clockwise by the rear internal gear, the planet gears rotate clockwise round the stationary sun gear. The 'output' carrier planet gears drive the 'output' carrier assembly and 'output' shaft clockwise, ie second gear.

Third gear is obtained when the direct clutch is applied; the power flow from the 'overdrive' planet gears and the forward clutch housing is then transferred to both the 'sun' gear and the 'output' internal gear. With the power flow through the 'overdrive' planetary gear set being a direct drive, and with both the sun gear and the internal gears of the 'output' planet gear set driving at converter turbine speed, the 'output' planetary gears act as wedges and drive the 'output' carrier assembly and output shaft together, ie direct drive, third gear.

In fourth gear, the 'overdrive' sun gear is held stationary by the fourth clutch being applied, then the 'overdrive' carrier being driven clockwise, the 'overdrive' planetary gears rotate clockwise also on their axes around the stationary sun gear. This causes the planetary gears to drive the 'overdrive' internal gear clockwise and so an 'overdrive' ratio is obtained through the 'overdrive' planetary gear set.

In reverse gear, the rear brake band is applied to hold the 'reaction' carrier stationary while the direct clutch is applied to supply clockwise power flow to the sun gear. Power flow from the 'overdrive' planetary gear set being a direct drive, the sun gear drives the 'reaction' planetary gears anti-clockwise which drives the 'reaction' internal gear ('output' carrier assembly) anti-clockwise, ie reverse gear.

1.2.3 Torque Converter Clutch

When a pre-determined speed is achieved in fourth gear, the torque converter clutch is enabled by the transmission control module through the pulse width modulated solenoid and a clutch plate provides a direct drive so reducing fuel consumption. Pulsing the solenoid causes the TCC valve to modulate pressure against the TCC. This pulsing or modulated pressure allows the TCC to slip slightly so providing a smooth apply and release of the TCC.

If the transmission fluid exceeds a temperature of 125°C the TCC will also apply in second and third gears to reduce friction generated in the torque converter.



1.2.4 *Pulse Width Modulated (PWM) Solenoid*

This solenoid provides the gradual apply and release of the torque converter clutch for increased shift quality, see TCC.

1.2.5 *Input And Output Speed Sensors (TISS) And (TOSS)*

The two speed sensors are of the magnetic induction type, and are mounted on the left hand side of the transmission – the input sensor forward of the transmission centre, and the output sensor close to the rear extension housing. The induced voltage in the input sensor is generated from machined serrations on the forward clutch housing, and in the output speed sensor by serrations on the rear carrier assembly. The information from these two sensors is used by the transmission control module (TCM) to determine whether the engine is running, vehicle speed, the gear ratio, the TCC slip, and the turbine speed.

1.2.6 *Shift Solenoids 'A' And 'B'*

Both solenoids are attached to the valve body and are 'normally open exhaust valves'. The TCM activates the solenoid by grounding through an internal 'quad driver', activates the shift valve and so controls shift pattern.

For solenoid operation see Table 'ACTIVE COMPONENTS FOR EACH GEAR RATIO'. Solenoid 'A' is usually grey in colour, and solenoid 'B' is usually green.

1.2.7 *Variable Force Solenoid / Motor (VFS)*

The force motor is attached to the valve body and controls shift quality, dependant upon engine load, based on information received from the TCM.

1.2.8 *Transmission Control Module (TCM)*

This unit is an electronic module which controls gear shift points and shift quality. Using data received from various sensors, the TCM is 'updated' every 25 milliseconds, and adapts to changes in engine load, altitude, and other conditions. Electrical signals are then transmitted to the shift solenoids which activate the shift valves for precise shift control.

The TCM, located behind the passenger side fascia, has also a diagnostic capability such that it continually monitors the transmission's conditions and stores the performance data in its memory. This information can then be downloaded and read using the Jaguar Diagnostic System.

If a serious fault occurs, the TCM removes all electrical power from the three solenoid valves on the valve block and the transmission reverts to a mechanical default condition; this condition allows only mechanical selection of reverse and one forward (2nd – second) gear.

1.2.9 *Pressure Switch Manifold (PSM)*

This is a gear range sensing device used by the TCM to sense the gear range that has been selected by the driver. The PSM, located on the valve body, contains five normally open pressure switches which under the various fluid pressures fed from the manual valve, provide system signals to the PCM which determines the gear range that the transmission is operating in.

1.2.10 *Transmission Temperature Sensor*

The temperature of the transmission fluid is monitored by this sensor which relays information to the TCM. If the temperature rises above a certain figure, then the torque converter clutch is applied, see Torque Converter Clutch. This sensor is contained in the internal transmission harness.

1.2.11 *Accumulators*

The accumulators act as shock absorbers to cushion the engagement of the transmission clutches. The clutch 'apply' fluid pressure on one side of the accumulator piston acts against the accumulator spring pressure and the accumulator fluid pressure on the opposite side of the piston. This sequence is damped by controlling the exhaust rate of the accumulator fluid. There are accumulators for the second, third and fourth clutches.



1.3 OIL PUMP AND INTERNAL VALVES

The oil pump is mounted in the transmission assembly situated between the torque converter and the transmission gears casing. The pump is a constant mesh spur gear type and the drive gear, being keyed to the torque converter hub, is driven at engine speed whenever the engine is running. The oil pump contains valves for pressure regulation, torque converter clutch (TCC) enable and shift, converter limiting, and reverse boost.

1.3.1 Pressure Regulator Valve Train

A pressure regulating valve maintains the transmission fluid at a constant pressure, to ensure correct operation of the transmission, directing fluid into the converter limit valve, and the pump suction circuit to regulate the pump output.

1.3.2 Reverse Boost Valve

The boost valve is moved towards the pressure regulating valve when activated by torque signal fluid pressure from the variable force motor, the regulating valve is then moved against the fluid supply from the pump, and so boosts the line pressures in relation to engine torque. When reverse gear has been selected, the reverse fluid pressure forces the reverse boost valve to move towards the pressure regulator valve to boost the line pressure.

1.3.3 Torque Converter Clutch Enable Valve

To retain the TCC in a released condition, the TCC shift valve is held by regulated converter feed fluid which passes through the enable valve to the TCC enable circuit.

1.3.4 Torque Converter Clutch Shift Valve

The TCC shift valve, being held in the release position by spring force and TCC enable fluid, permits regulated converter feed fluid to pass through the valve and enter the TCC release circuit. To apply the TCC, enable fluid exhausts and the valve is shifted by signal fluid pressure

1.3.5 Converter Limiting Valve

This valve permits converter feed pressure from the pressure regulator valve to enter the regulated converter feed circuit. Excess converter feed pressure causes the limit valve to move against its spring pressure, and so the converter feed fluid is opened to exhaust.



1.4 VALVES IN THE VALVE BODY

The valve body contains: the accumulator valve, the actuator limit valve, the TCC apply valve, the manual valve, the 3 - 4 shift valve, the 2 - 3 shift valve, and the 1 - 2 shift valve.

1.4.1 Torque Signal Compensatory Valve

This valve is located in the accumulator housing, and torque signal fluid pressure is fed to it in each gear range. The spring in the valve dampens any pressure irregularities in the torque signal fluid pressure that are caused by the operation of the force motor.

1.4.2 Checkball Valves

There are 11 checkball valves, located in the valve block and transmission case, see Figs. 1 and 2. The function of each is described below.

(1) Overrun Clutch

Seats to direct D321 fluid through an orifice and into the overrun clutch, thereby helping to control the apply rate of the overrun clutch. When the overrun clutch releases, the exhausting fluid unseats and flows past the checkball and into the D321 circuit. This allows a faster exhaust of fluid and a quicker release of the overrun clutch.

(2) Second Accumulator

Seats to direct accumulator fluid through an orifice before entering the second gear accumulator circuit, helping to control the rate at which the second gear clutch fluid exhausts from the rear servo and the release rate of the intermediate clutch.

(3) Front Band Apply

Seats to direct Front Band Apply fluid through an orifice to help control the apply rate of the front band. When the band releases, the exhausting fluid unseats and flows past the checkball, thus allowing a faster release of the front band.

(4) Second Gear Clutch

Seats to direct 2-3 fluid through an orifice and into the second gear clutch (intermediate clutch circuit; this helps to control the apply rate of the intermediate clutch. When the clutch releases, the exhausting fluid unseats and flows past the checkball and into the 2-3 circuit, allowing a faster exhaust of fluid and a quicker release of the intermediate clutch.

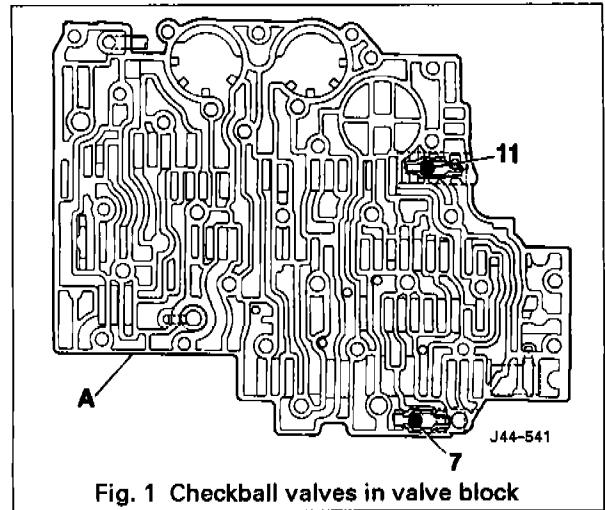

Fig. 1 Checkball valves in valve block

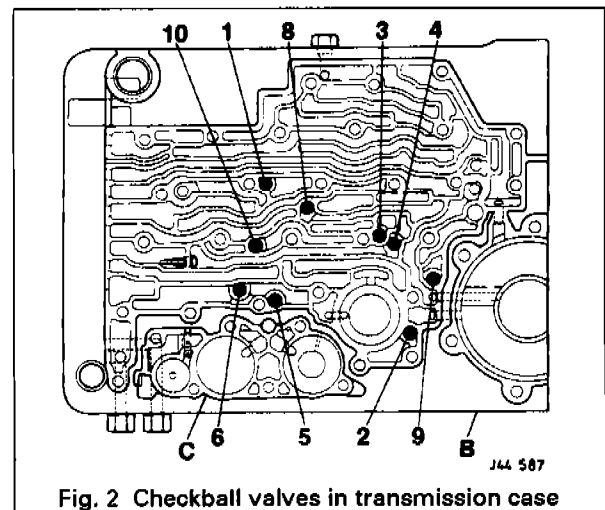

Fig. 2 Checkball valves in transmission case



(5) Third Accumulator

Seats to direct accumulator fluid through an orifice before entering the third accumulator circuit. This helps to control the rate at which the third clutch fluid exhausts from the accumulator and the release rate of the direct clutch.

(6) Fourth Accumulator

Seats to direct accumulator fluid through an orifice before entering the fourth accumulator circuit; this helps to control the rate at which the fourth clutch fluid exhausts from the accumulator and the release rate of the fourth clutch.

(7) Low / Reverse (Shuttle Valve)

Allows Low fluid to enter the Rear Band Apply circuit, when manual first has been selected (not selectable currently), or Reverse fluid, to enter the rear band apply circuit.

(8) Third Gear Clutch

Seats to direct accumulator fluid through an orifice and into the third clutch circuit; this helps to control the apply rate of the direct clutch in third gear. When the clutch releases, the exhausting fluid unseats and flows past the checkball and into the third clutch circuit, allowing a faster exhaust of fluid and a quicker release of the direct clutch.

(9) Reverse

Seats to direct reverse fluid through an orifice; this helps to control the apply rate of the direct clutch in reverse gear. When the clutch releases, the exhausting fluid unseats and flows past the checkball, allowing a faster exhaust of fluid and a quicker release of the fourth clutch.

(10) Fourth Clutch

Seats to direct reverse fluid through an orifice; this helps to control the rate at which the fourth clutch is applied. When the fourth clutch releases, the exhausting fourth clutch fluid unseats and flows past the checkball, allowing a faster exhaust of fluid and a quicker release of the fourth clutch.

(11) Third Clutch / Reverse (Shuttle Valve)

Allows either, third clutch fluid (when third gear has been selected), or Reverse fluid, to enter the third / reverse circuit.



1.4.3 Active Components For Each Gear Ratio

Note: This table is in two parts for convenience only: the upper table for Park, Neutral, Reverse and Drive for all automatic forward gears, and the lower table for Manual 3 and Manual 2 gear ranges.

Range	P and N	R	D			
Gear		Reverse	1	2	3	4
Shift solenoid 'A' @	On #	On #	On	Off	Off	On
Shift solenoid 'B' @	Off #	Off #	Off	Off	On	On
Fourth clutch						Applied
Over-run clutch						
Overdrive roller clutch	Holding	Holding	Holding	Holding	Holding	Over-running
Forward clutch			Applied	Applied	Applied	Applied
Direct clutch		Applied			Applied	Applied
Front band						
Intermediate sprag clutch			*	Holding	Over-running	Over-running
Intermediate clutch				Applied	Applied	Applied
'LO' roller clutch			Holding	Over-running	Over-running	Over-running
Rear band		Applied				

Range	3			2	
Gear	1	2	3	1	2
Shift solenoid 'A' @	On	Off	Off	On	Off
Shift solenoid 'B' @	Off	Off	On	Off	Off
Fourth clutch					
Over-run clutch	Applied	Applied	Applied	Applied	Applied
Overdrive roller clutch	Holding	Holding	Holding	Holding	Holding
Forward clutch	Applied	Applied	Applied	Applied	Applied
Direct clutch			Applied		
Front band					Applied
Intermediate sprag clutch	*	Holding	Over-running	*	Holding
Intermediate clutch		Applied	Applied		Applied
'LO' roller clutch	Applied	Over-running	Over-running	Applied	Over-running
Rear band		Applied			

@ The solenoid's state follows a shift pattern dependent on the vehicle speed, throttle position, and the selected performance mode; it does NOT depend upon the selected gear.

Mode dependent – correct in 'SPORT', but both OFF in 'NORMAL'

* Holding but not effective

The above table shows component function during acceleration.



1.5 HYDRAULIC CIRCUIT DIAGRAMS

Key To Hydraulic Circuit Diagrams (commencing on page 12)









- | | |
|--------------------------------|---------------------------------------|
| 1. Torque converter | 15c. 4th accumulator |
| 2. Overrun clutch assembly | 16. Accumulator valve |
| 3. 4th clutch | 17. Actuator limit valve |
| 4. Forward clutch | 18. PWM solenoid |
| 5. Direct clutch | 19. TCC regulator |
| 6. Intermediate clutch | 20. Force motor |
| 7. Pump assembly | 21. Manual valve |
| 8. TCC shift valve | 22. Pressure switch manifold |
| 9. TCC enable valve | 23. 1 – 2 shift valve |
| 10. Converter limit valve | 24. 2 – 3 shift valve |
| 11. Pressure regulator | 25. 3 – 4 shift valve |
| 12. Boost valve | 26. Rear servo assembly |
| 13. Pump | 27. Front servo assembly |
| 14. Transmission fluid cooler | 28. Filter |
| 15. Accumulator housing | 29. Filter |
| 15a. Torque signal compensator | 30. Sump pan (shown including filter) |
| 15b. 3rd accumulator | 31. Filter |

Checkball Valves

Note: All checkball valves are in the transmission case except where shown otherwise.

- | | |
|----------------------|---|
| #1. Overrun clutch | #7. Lo / third in the control valve body |
| #2. 2nd accumulator | #8. 3rd clutch |
| #3. Front band apply | #9. Reverse |
| #4. Second clutch | #10. 4th clutch |
| #5. 3rd accumulator | #11. 3rd clutch / reverse in the control valve body |
| #6. 4th accumulator | |

Pressures

- | | | | |
|---|---------------------------|---|-----------------------|
|  | INTAKE AND DECREASE |  | SOLENOID SIGNAL 'OFF' |
|  | CONVERTER AND LUBRICATION |  | ACCUMULATOR |
|  | MAIN PRESSURE |  | ACTUATOR FEED |
|  | SOLENOID SIGNAL 'ON' |  | TORQUE SIGNAL |

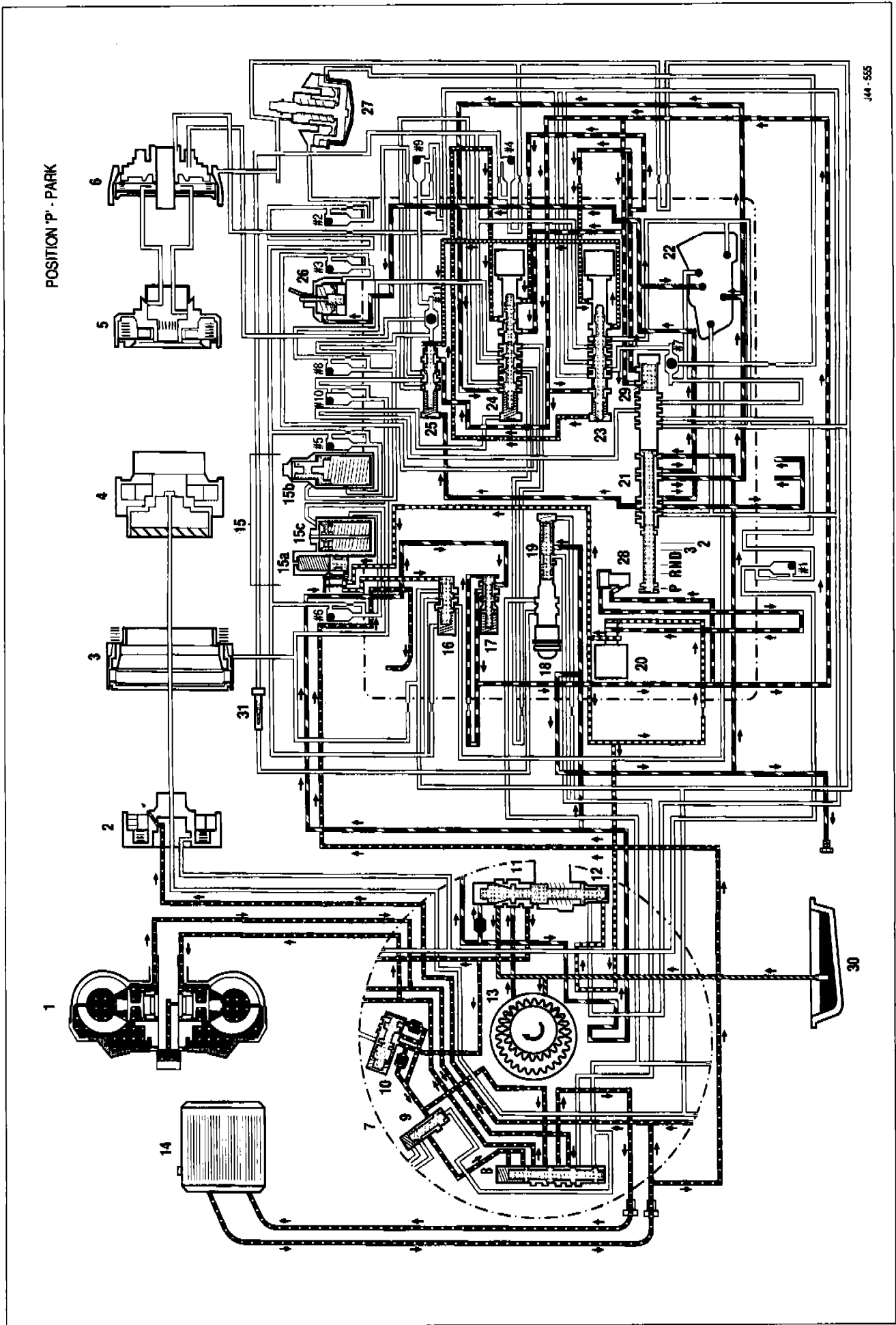

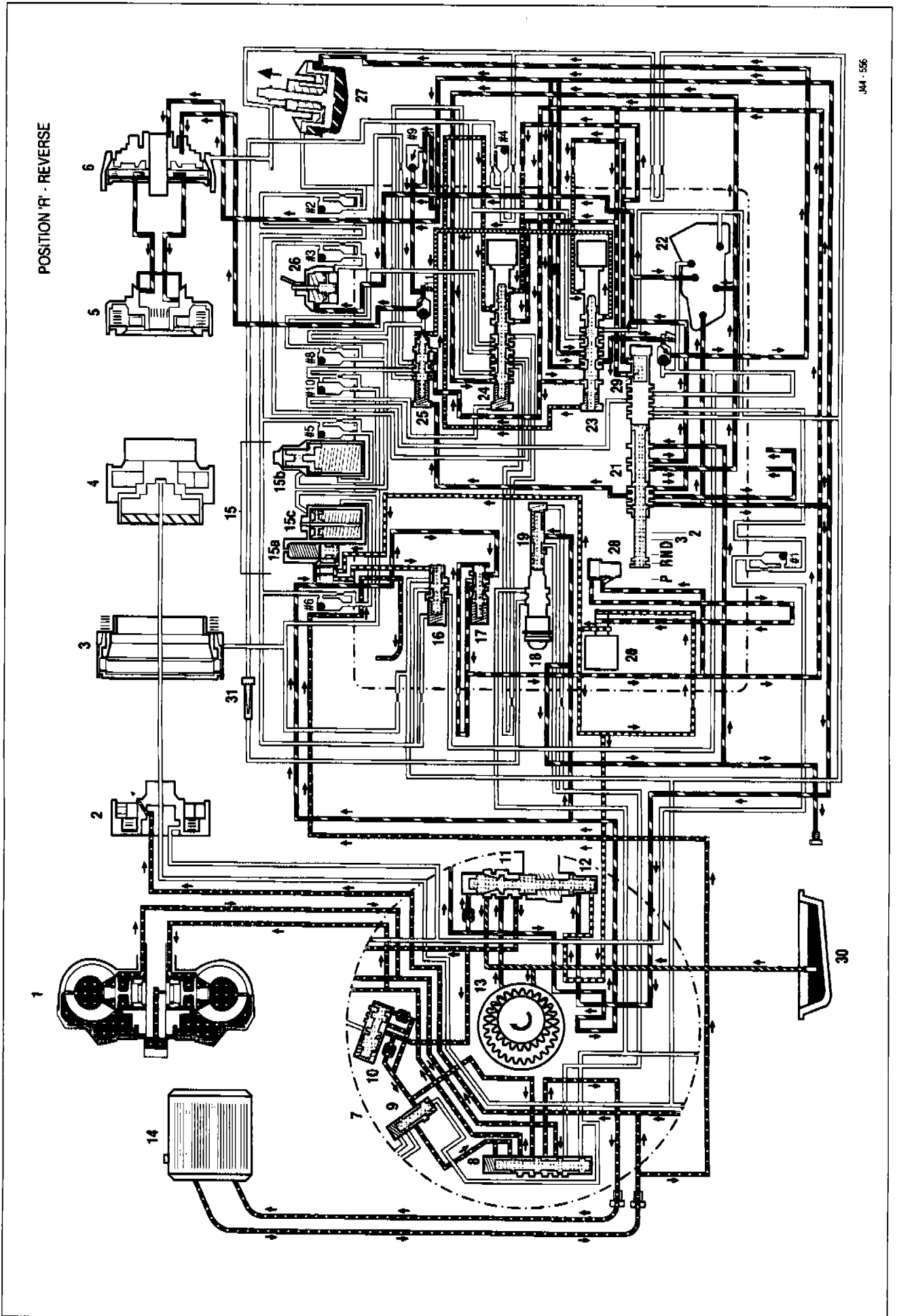

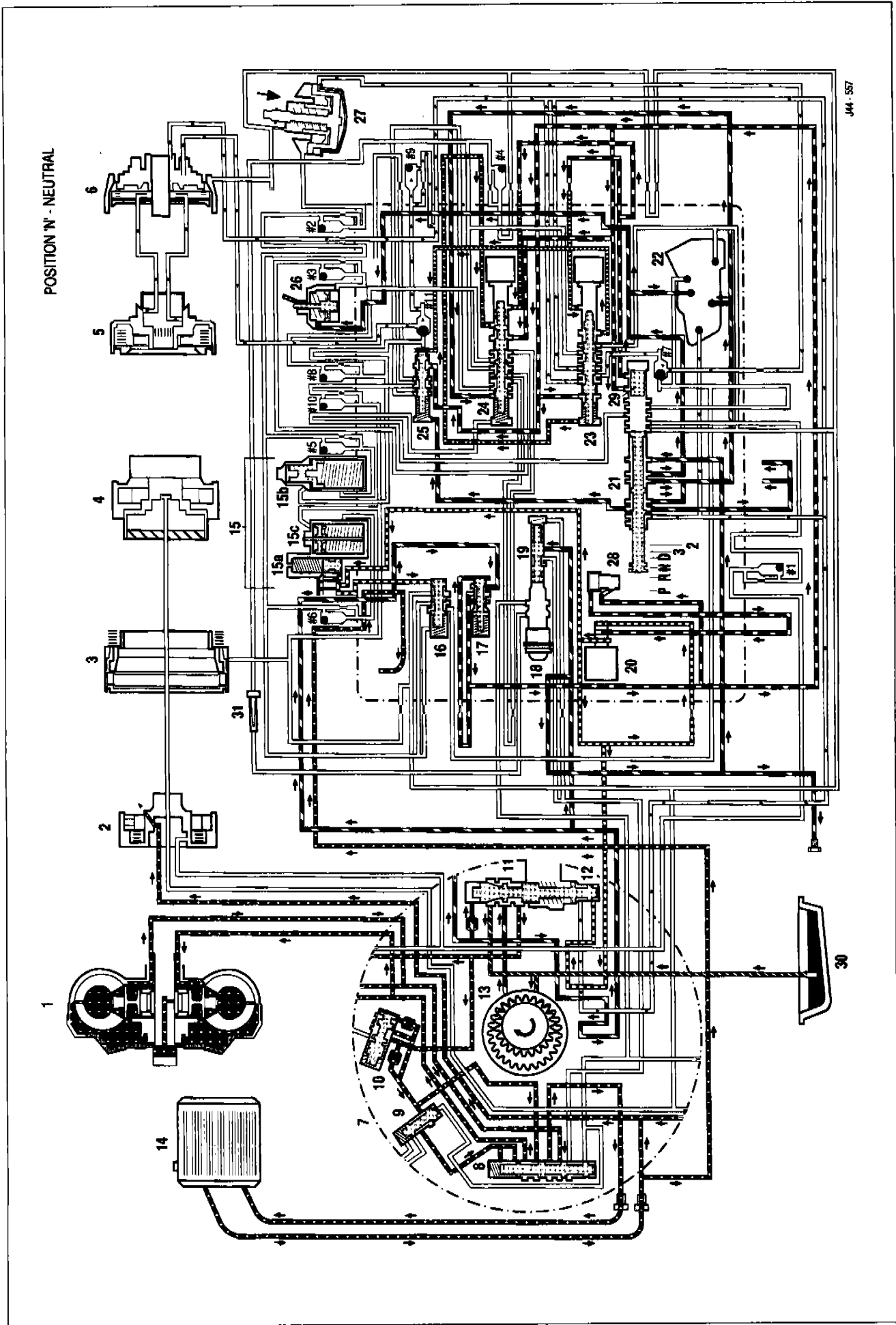



POSITION 'D' - DRIVE - 1st GEAR

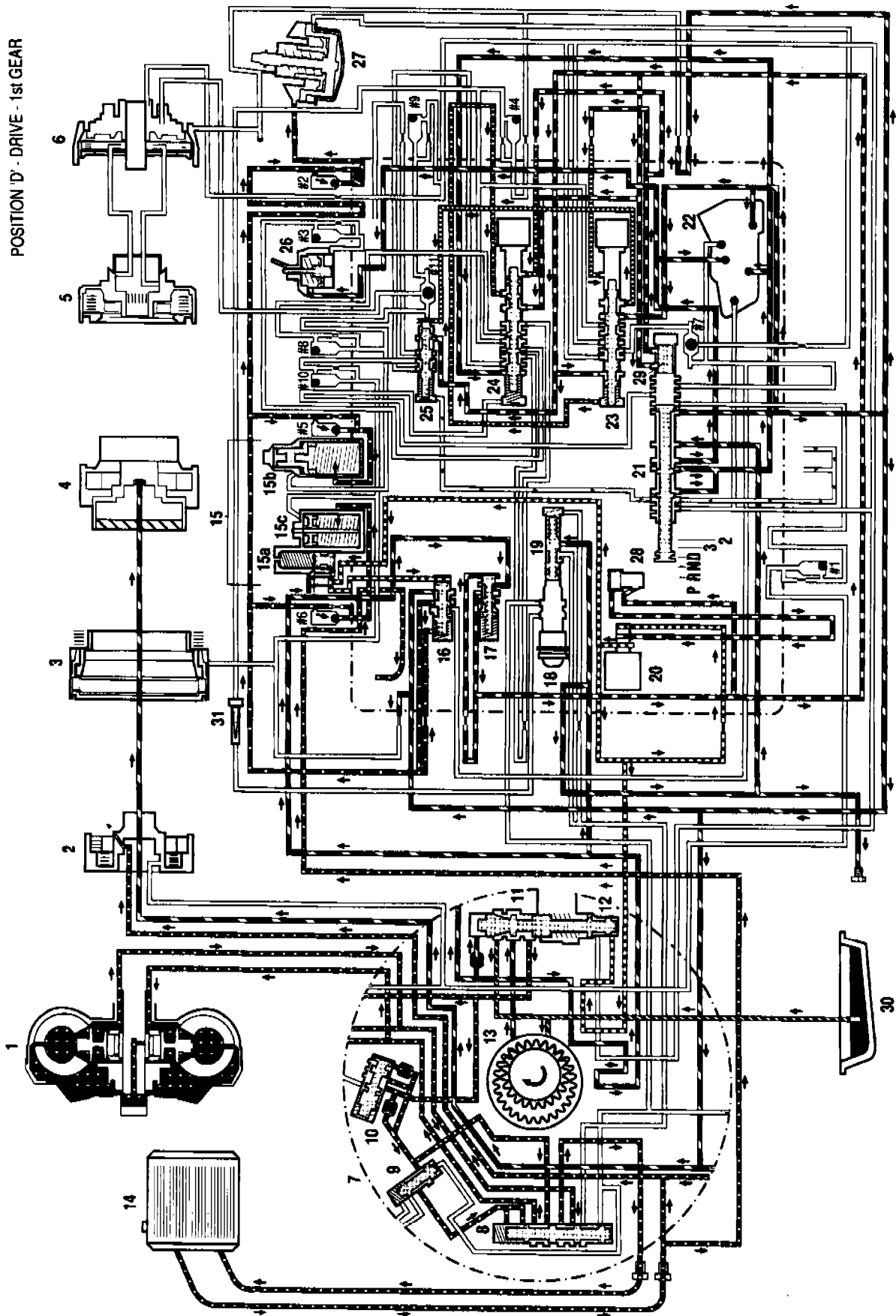

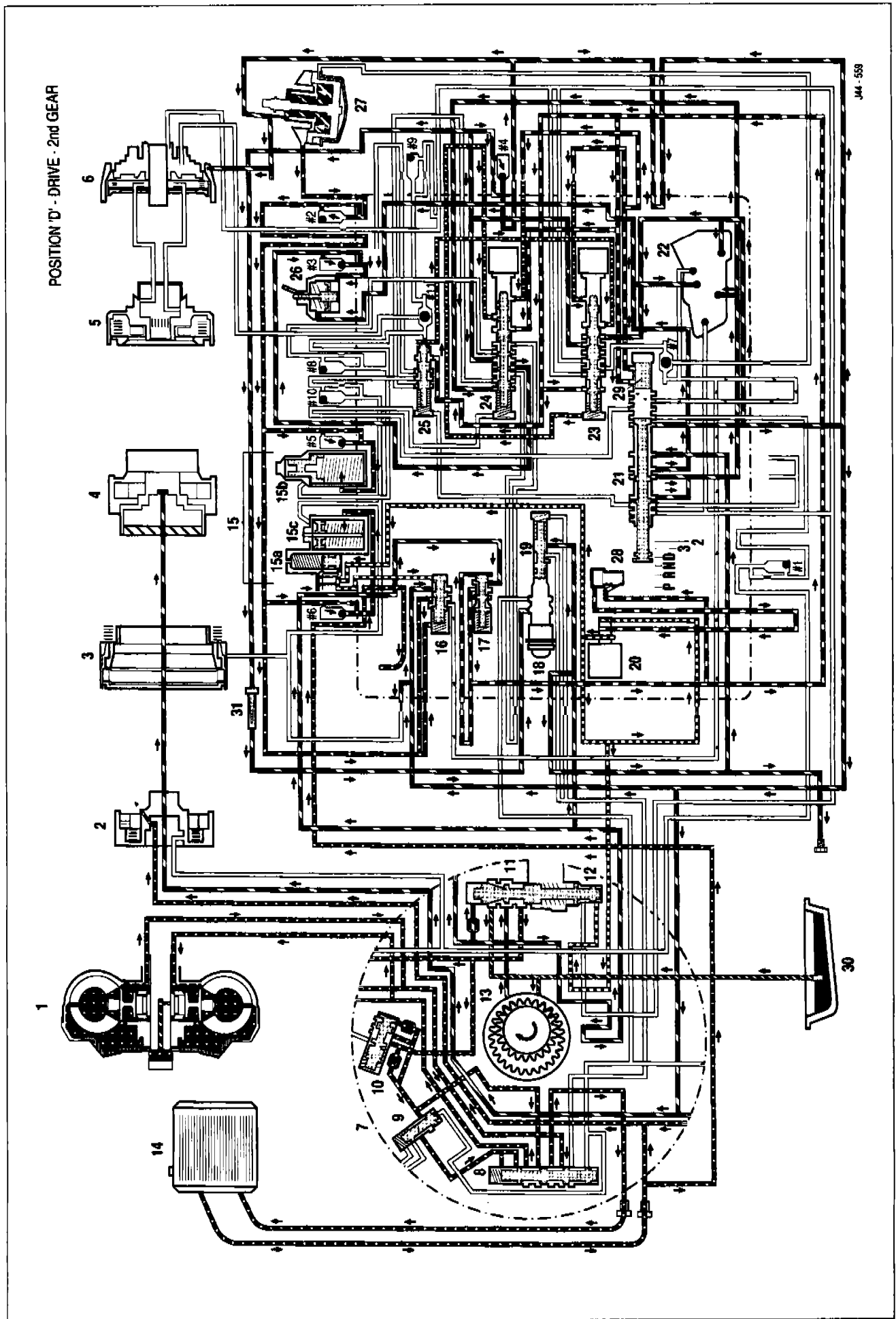



POSITION 'D' - DRIVE - 3rd GEAR

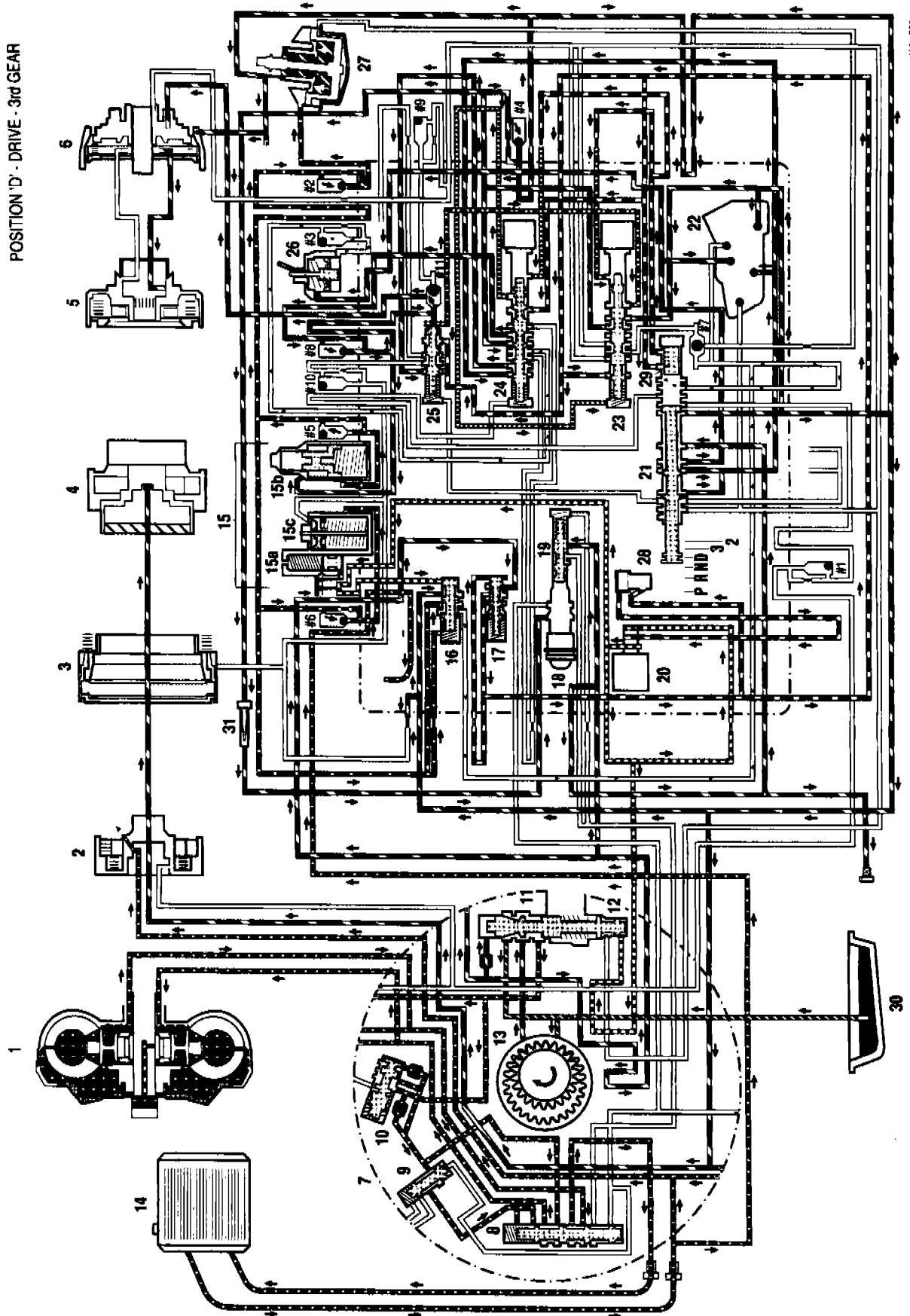

J44-560

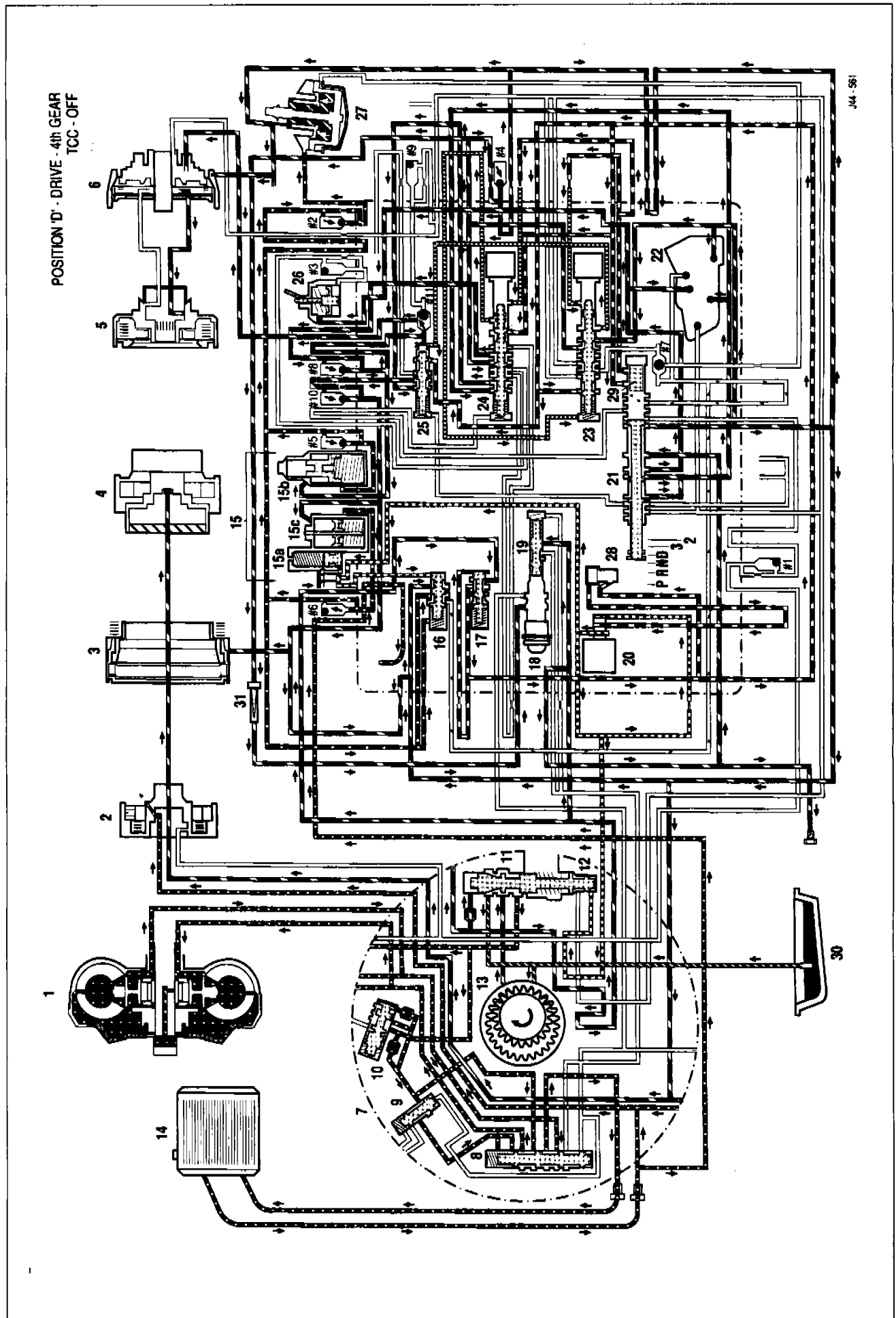



POSITION 'D' - DRIVE - 4th GEAR 'LOCK-UP'
TCC - ON

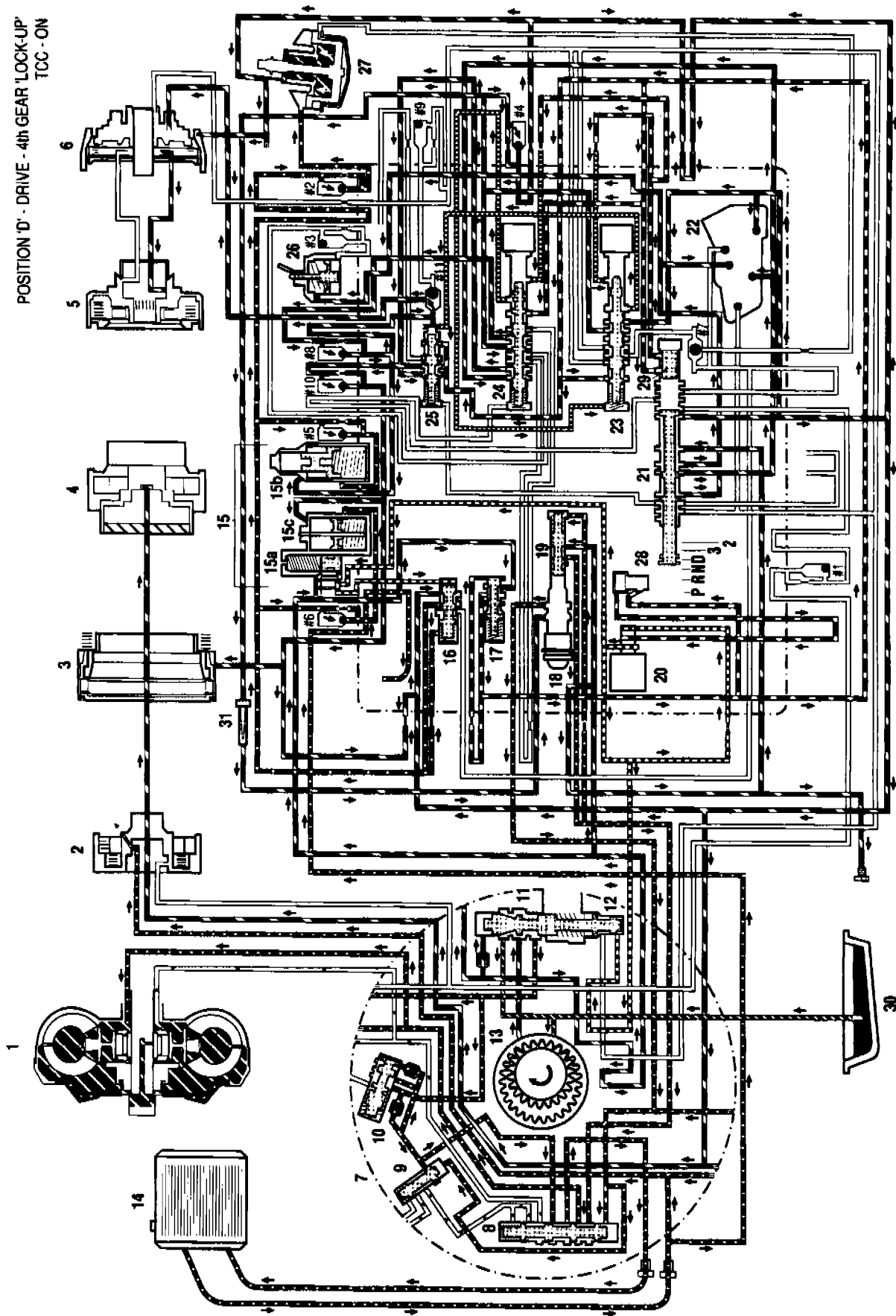

44-562

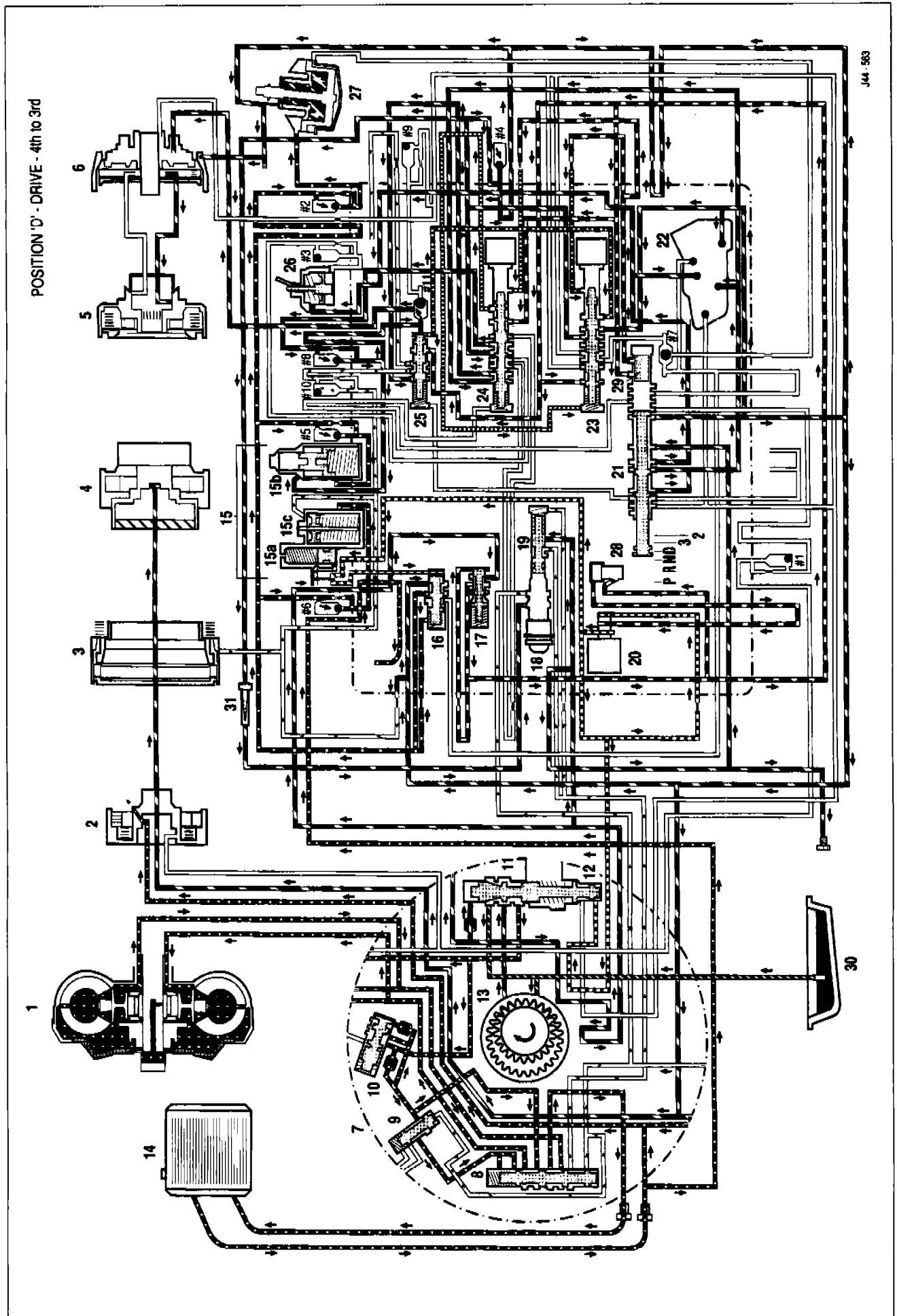

J44-583



POSITION 'D' - DRIVE - 3rd to 2nd

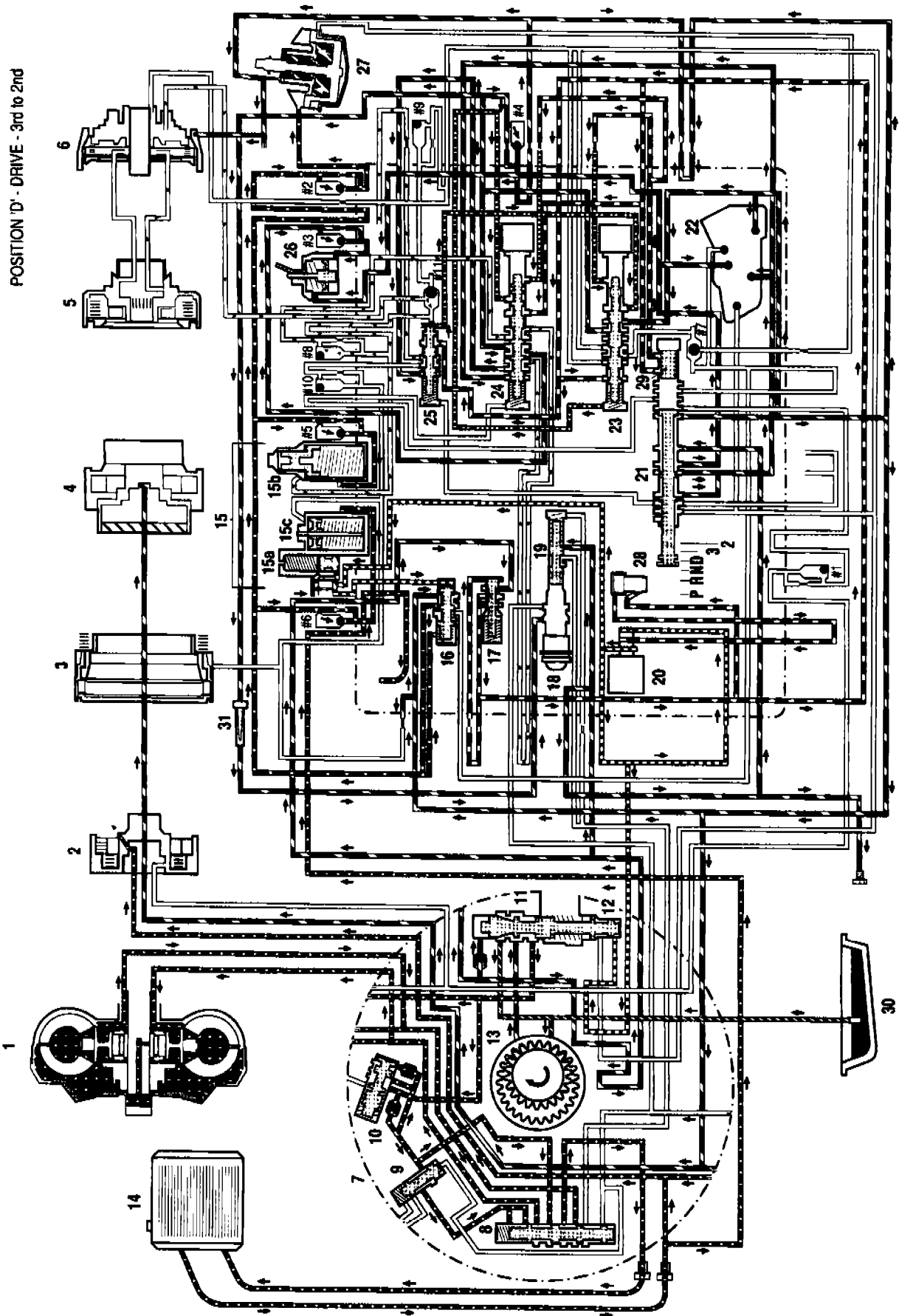

JA4-564

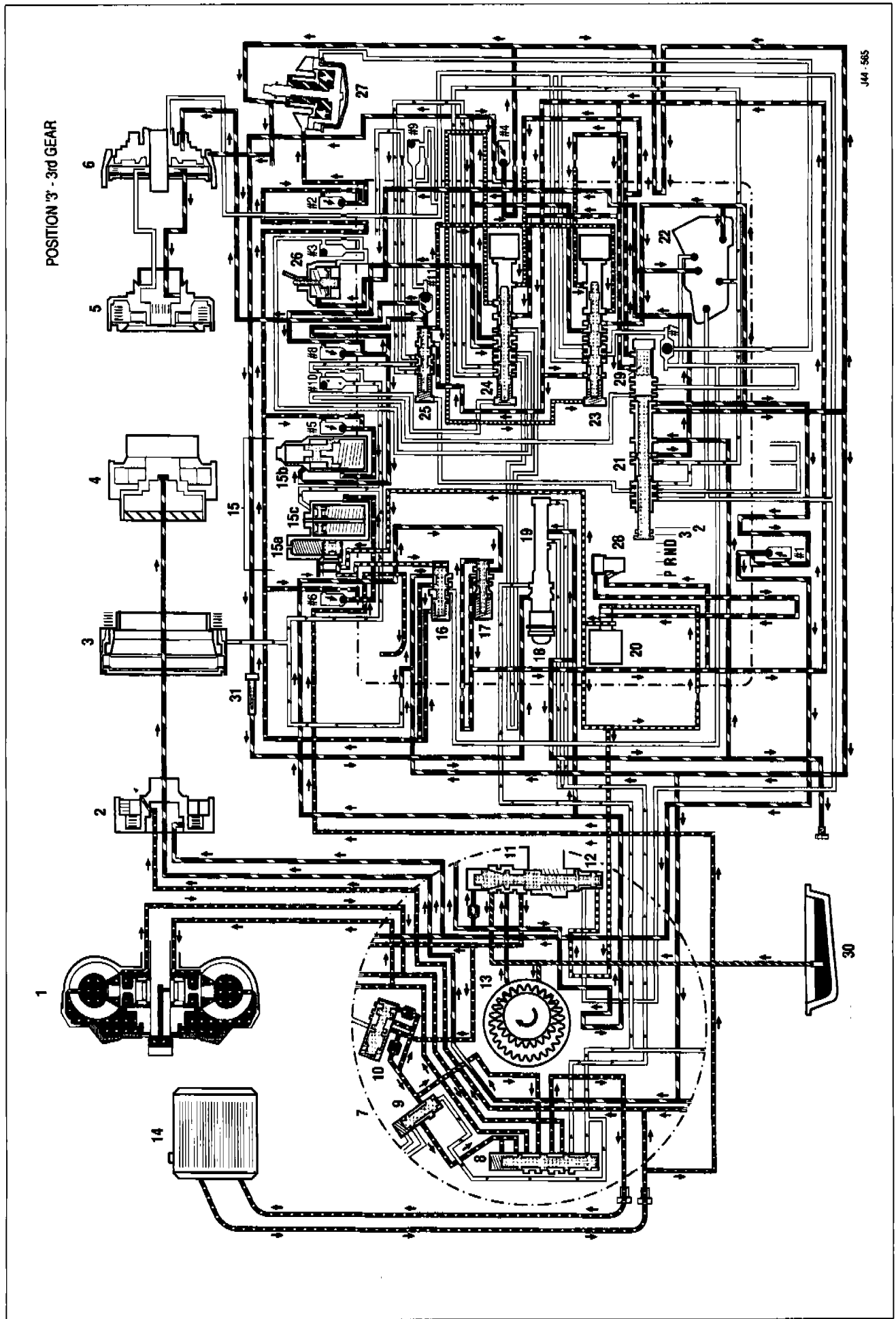

J44-585



POSITION '2' - 2nd GEAR

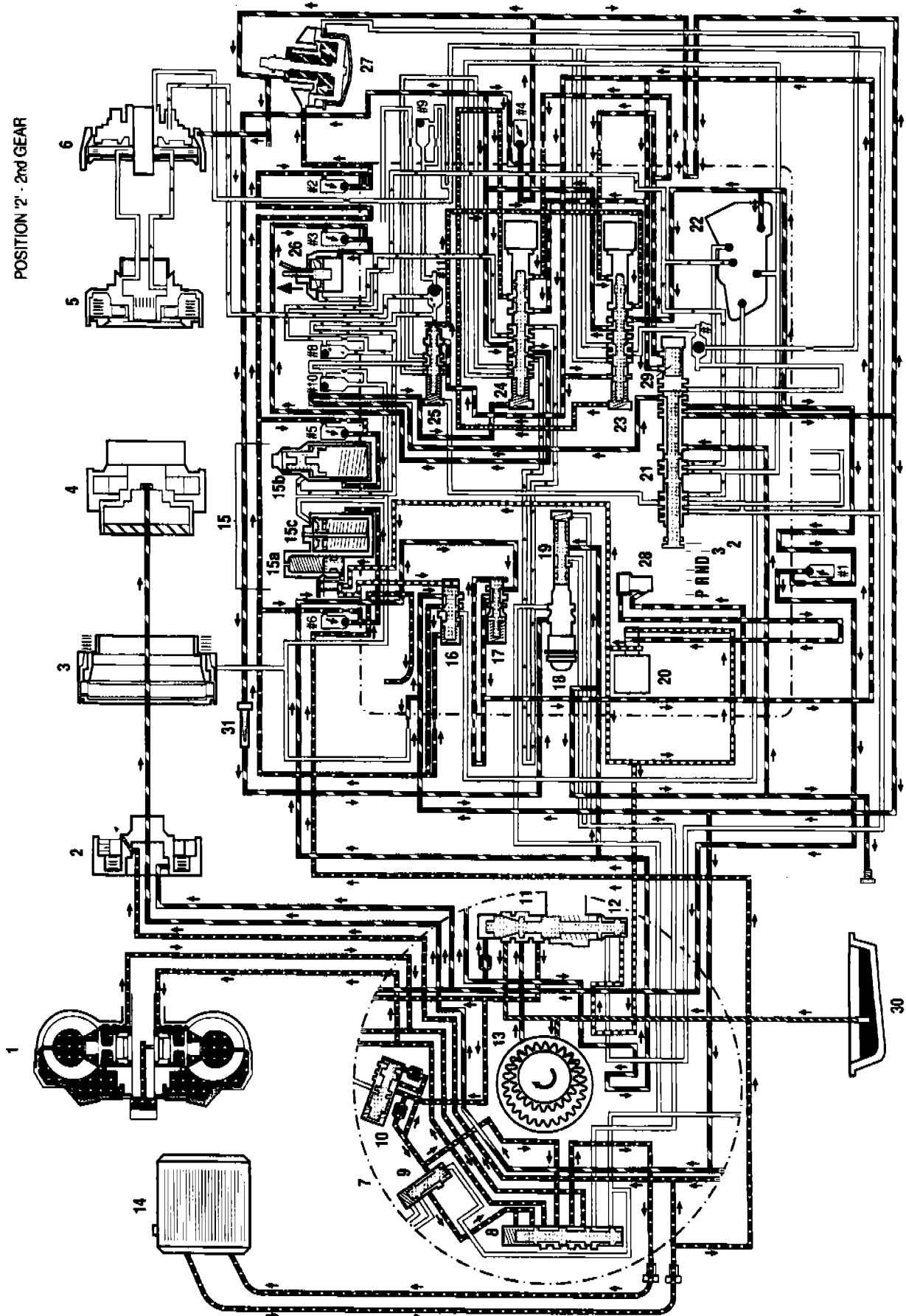

J44-566



1.6 FAULT DIAGNOSIS

The following checks are intended as a guide to diagnosis of possible mechanical faults in the 4L80-E hydraulic transmission unit; electrical faults are covered in the Electrical Diagnostic Manual. When the fault involves a leak, it is recommended that it is located by the use of a crack detection fluid, eg Met-L-Check, which is available in spray form and permits the leak to be located after a short test drive.

1.6.1 Initial Checks

Note: Before attempting diagnosis, ensure that the following settings are checked:

Transmission oil level

Note: This oil level can only be checked correctly when the transmission is at normal operating temperature

- Ensure that the transmission is at normal operating temperature of 90°C by conducting a 15 to 20 mile road test. If starting from cold, check for presence of oil on dipstick at idle in Park to the 'Cold' reference mark before start of road test.
- Check that the vehicle is on level ground.
- Select 'P' Park.
- Firmly apply the parking and foot brakes and run the engine at idle speed.
- To ensure that the system is primed, slowly move the selector lever through all the gear positions.
- With the engine still running, engage 'P' Park, withdraw the dipstick and wipe with a lint free cloth.
- Replace the dipstick slowly and withdraw it noting the level.
- Top up as required and recheck the level.

1.6.2 Engine Tune

Kick-down switch adjustment

- Refer to VSM Section 8.2.

1.6.3 Stall Test

- Ensure the transmission is at normal running temperature.
- Fully apply the parking brake.
- Start the engine.
- Fully depress the footbrake.
- Select position 'D'– Drive.
- Fully depress the accelerator ('kick-down' detent fully depressed).
- Note the tachometer reading.
- Compare the tachometer reading to the specification.

CAUTION: This test must not last more than 5 seconds. Always allow the engine to idle for at least 2 minutes between tests to allow the transmission fluid to cool down. Do not carry out more than three tests in any half-hour.

1.6.4 Road Test

- Fully check all shift speeds and note. Compare the results with the specification in addition to general observations of transmission behaviour, noises, leaks etc., and consult the following Fault Finding Chart.

CAUTION: When renewing the transmission, ALWAYS flush out the oil cooler and feed and return pipes.

1.6.5 Electrical Checks

- If any electrical component fault is suspected, refer to Electrical Diagnostic Manual (EDM) to verify the failure mode before a repair or replacement is attempted.



1.6.6 Transmission Fault Codes

Fault Finding is carried out by the use of the portable diagnostic unit (PDU). All types of fault, whether mechanical or electrical, cause transmission fault codes to be displayed on the PDU. Refer to the Electrical Diagnostic Manual (EDM) for electrical faults.

P1608	Watchdog Fault
P0702	Transmission Control System Electrical
P0705	Transmission Range Sensor Circuit Malfunction
P0706	Transmission Range Sensor Circuit Range / Performance
P0715	Input / Turbine Speed Sensor Circuit Malfunction
P0716	Input / Turbine Speed Sensor Circuit Range / Performance
P0720	Output Speed Sensor Circuit Malfunction
P0721	Output Speed Sensor Circuit Range / Performance
P0722	Output Speed Sensor Circuit No Signal
P0726	Engine Speed Input Circuit Range / Performance
P0727	Engine Speed Input Circuit No Signal
P1739	Transmission Component Slipping
P0742	Torque Converter Clutch System Stuck On
P7043	Torque Converter Clutch System Electrical
P0751	Shift Solenoid 'A' Performance
P0753	Shift Solenoid 'A' Electrical
P0756	Shift Solenoid 'B' Performance
P0758	Shift Solenoid 'B' Electrical
P1775	Transmission System Check Engine Lamp Fault
P1776	Ignition Retard Request Duration Fault
P1780	Torque Reduction Signal Malfunction
P1781	Torque Signal Malfunction Range / Performance
P1786	Mode Switch Input Malfunction
P1790	Throttle Position Signal System Range / Performance
P1791	Throttle Position Electrical Failure
P1794	System Voltage Malfunction



1.7 SERVICE OPERATIONS

1.7.1 Rear Servo Assembly, Renew (V12)

SRO 44.34.13

- Raise hood and fit fender cover.
- Raise the vehicle on a ramp.
- Drain the transmission lubrication system, see VSM sub-section 8.2.16.
- Remove the fluid pan, see VSM sub-section 8.2.18.
- Remove the fluid filter, see VSM sub-section 8.2.21.
- Remove the transmission internal harness, see VSM sub-section 8.2.22.
- Remove the internal lubrication pipe, see VSM sub-section 8.2.23.
- Remove the manual detent spring assembly, see VSM sub-section 8.2.25.
- Remove the internal dipstick stop, see VSM sub-section 8.2.24.
- Remove the valve body and accumulator assembly, see sub-section 1.7.3 (this manual); check the condition of the gasket.
- Release and remove rear servo cover securing bolts and remove rear servo cover.
- Remove rear servo gasket and discard.
- Remove rear servo piston assembly (Fig. 1) and place aside.
- Clean relevant parts and faces and inspect all seals for condition.
- Fit stepped gauge pin JD 193 (Fig. 2) to rear servobore.
- Fit and align rear band; apply pin checking tool JD 192 (2 Fig. 3) to the main case. Note the orientation.
- Fit and tighten the checking tool to the main case using two of the servo cover securing bolts.

Note: Ensure the stepped gauge pin (1 Fig. 3) moves freely in the tool and pin bore.

- Apply torque to the nut on the checking tool – 34Nm.
- From the gauging steps located on the gauge pin, determine the band apply pin from the selection chart.
- Release torque from the checking tool nut.
- Release and remove the checking tool to main case securing bolts.
- Remove the checking tool and place aside.
- Remove the stepped gauge pin and place aside.
- Place new rear servo assembly to front.
- Remove servo apply pin retaining clip.
- Remove apply pin and spring assembly.
- Remove apply pin from washer, spring, retainer assembly and place pin aside.

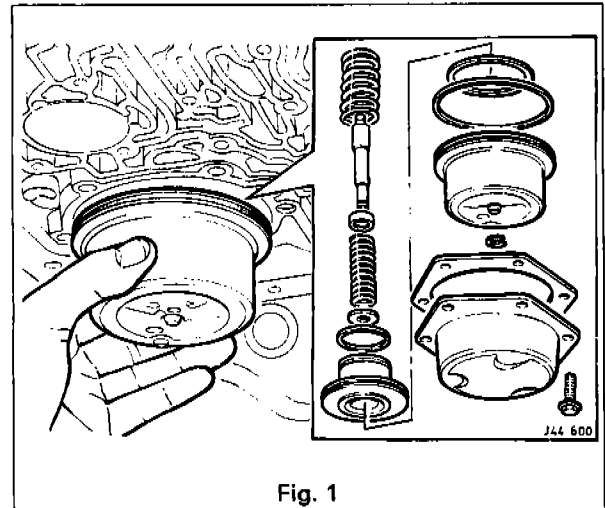

Fig. 1

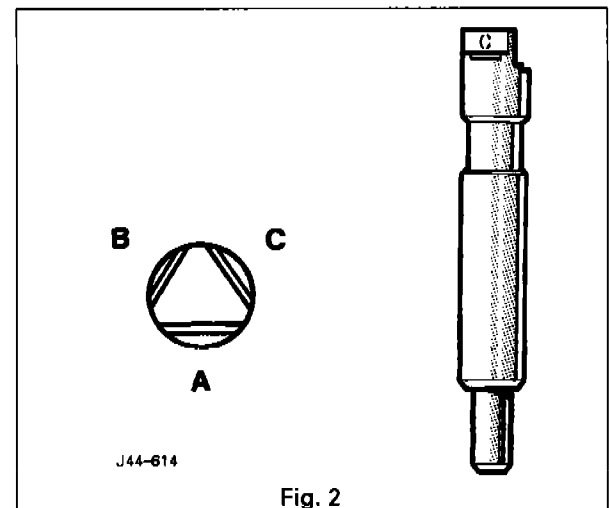

Fig. 2

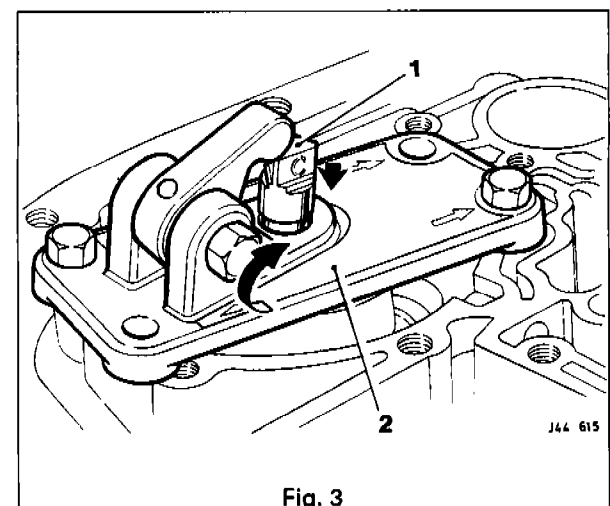

Fig. 3



- Fit new selected apply pin to washer, spring, retainer assembly.
- Fit apply pin assembly to rear servo piston assembly.
- Fit and seat servo apply pin retaining clip.
- Lubricate rear servo assembly.
- Fit rear servo assembly to main case.
- Fit new rear servo cover gasket.
- Fit and align rear servo cover to main case.
- Fit and tighten rear servo cover securing bolts, tightening the bolts evenly to prevent cover distortion.
- Refit the valve body assembly, see sub-section 1.7.3 (this manual), checking that all nine checkballs are in their correct positions.
- Refit the internal dipstick stop, see VSM sub-section 8.2.24.
- Refit the manual detent spring, see VSM sub-section 8.2.25.
- Refit the internal lubrication pipe, see VSM sub-section 8.2.23.
- Refit the internal harness O-ring seal and multipin socket, see VSM sub-section 8.2.22.
- Refit the fluid filter, see VSM sub-section 8.2.21.
- Refit the fluid pan, see VSM sub-section 8.2.18.
- Lower the vehicle on the ramp.
- Refill the transmission with fluid, see VSM sub-section 8.2.16.
- Lower the hood.

1.7.2 Front Servo Assembly, Renew (4.0 Liter SC and V12)

SRO 44.34.17

- Raise hood and fit wing cover.
- Raise the vehicle on a ramp.
- Drain the transmission lubrication system, see VSM sub-section 8.2.16.
- Remove the fluid pan, see VSM sub-section 8.2.17 (4.0 liter SC) and sub-section 8.2.18 (V12).
- Remove the fluid filter, see VSM sub-section 8.2.21.
- Remove the transmission internal harness multipin socket O-ring, see VSM sub-section 8.2.22.
- Remove the internal lubrication pipe, see VSM sub-section 8.2.23.
- Remove the manual detent spring assembly, see VSM sub-section 8.2.25.
- Remove the internal dipstick stop, see VSM sub-section 8.2.24.
- Remove the valve body and accumulator assembly, see sub-section 1.7.3 (this manual), check the condition of the gasket.
- Place front servo piston, pin and spring assembly aside, see Fig. 1.

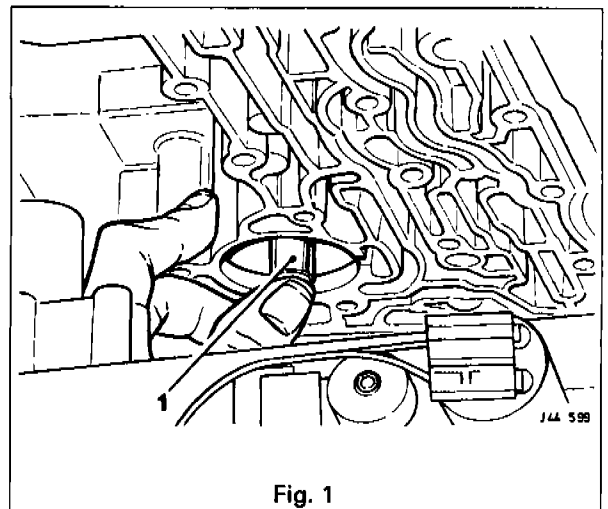



- Place new front servo assembly to front.
- Lubricate servo piston assembly.
- Refit front servo assembly.
- Refit the valve body assembly, see sub-section 1.7.3 (this manual), checking that all nine checkballs are in their correct positions.
- Refit internal dipstick stop, see VSM sub-section 8.2.24.
- Refit manual detent spring assembly, see VSM sub-section 8.2.25.
- Refit internal lubrication pipe, see VSM sub-section 8.2.23.
- Fit new internal harness multipin socket O-ring seal, see VSM sub-section 8.2.22.
- Refit fluid filter, see VSM sub-section 8.2.21.
- Refit fluid pan, see VSM sub-section 8.2.17 (4.0 liter SC) and sub-section 8.2.18 (V12).
- Lower the vehicle on the ramp.
- Refill the transmission with fluid, see VSM sub-section 8.2.16.
- Lower the hood.

1.7.3 Valve Body and Accumulator – Remove For Access & Refit (4.0 liter SC and V12)

SRO 44.40.05/90

- Open the hood and fit suitable fender cover.
- Raise the vehicle on a ramp.
- Drain the lubrication system, see VSM sub-section 8.2.16.
- Remove the fluid pan, see VSM sub-section 8.2.17 (4.0 liter SC) and sub-section 8.2.18 (V12).
- Remove the fluid filter, see VSM sub-section 8.2.21.
- Remove the internal harness, multipin socket O-ring, see VSM sub-section 8.2.22.
- Remove the internal lubrication pipe, see VSM sub-section 8.2.23.
- Remove the manual detent spring assembly, see VSM sub-section 8.2.25.
- Remove the internal dipstick stop, see VSM sub-section 8.2.24.
- Release and remove the remaining valve body to main case securing bolts (two bolts also secure harness clips).
- Lower the valve body assembly and place on a clean surface.
- Remove the front servo piston assembly.
- Retrieve the check balls from the valve body, see Figs. 1 and 2.

CAUTION: Do not use a magnet.

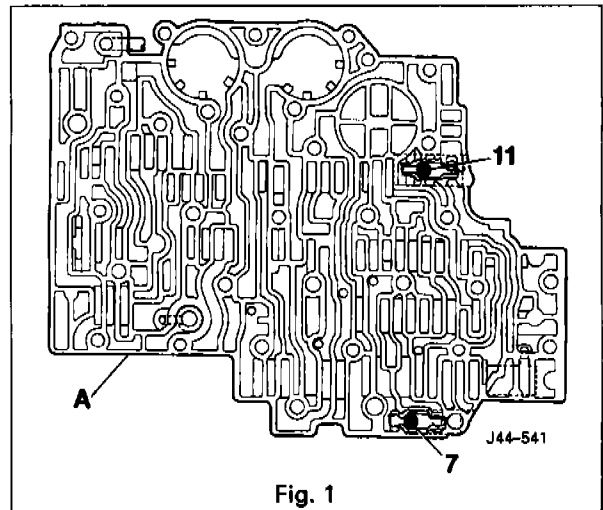

Fig. 1

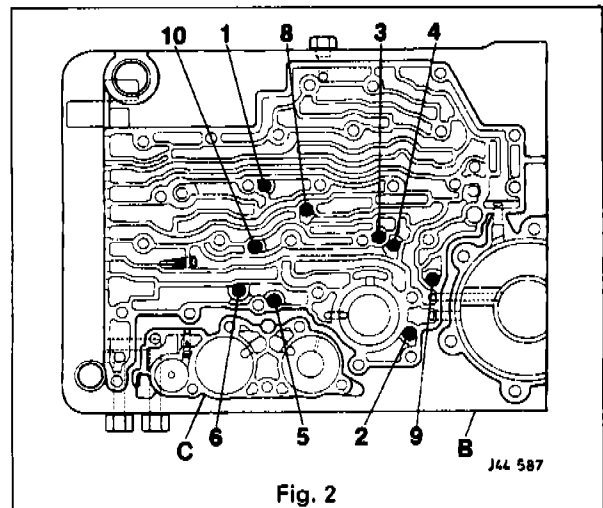

Fig. 2



- Remove and discard the gasket.
- Remove the conical filter from the valve body.
- Clean the relevant parts and faces.
- Fit the conical filter to the valve body.
- Fit a new gasket to the valve body.
- Fit the check balls to the valve body spacer plate; a small amount of petroleum jelly will help to keep the balls in position.
- Lubricate the front servo piston assembly.
- Fit the front servo piston to the main case, holding the piston seated with thumb pressure until the valve body is raised.
- Fit and align the valve body assembly to the main case using all new gaskets.
- Align the manual valve with the detent lever peg.
- Fit and tighten the valve body to main case securing bolts (two bolts also secure the harness clips).
- Refit the internal dipstick stop, see VSM sub-section 8.2.24.
- Refit the manual detent spring, see VSM sub-section 8.2.25.
- Refit the internal lubrication pipe, see VSM sub-section 8.2.23.
- Refit the internal harness O-ring seal and multipin socket, see VSM sub-section 8.2.22.
- Refit the fluid filter, see VSM sub-section 8.2.21.
- Refit the fluid pan, see VSM sub-section 8.2.17 (4.0 liter SC) and sub-section 8.2.18 (V12).
- Lower the vehicle on the ramp.
- Refill the transmission with fluid, see VSM sub-section 8.2.16.
- Remove the fender cover and close the hood.

1.7.4 Valve Body Assembly, Renew (4.0 liter SC and V12)

SRO 44.40.06

- Raise hood and fit wing cover.
- Raise the vehicle on a ramp.
- Drain the transmission lubrication system, see VSM sub-section 8.2.16.
- Remove the fluid pan, see VSM sub-section 8.2.17 (4.0 liter SC) and sub-section 8.2.18 (V12).
- Remove the fluid filter, see VSM sub-section 8.2.21.
- Remove the transmission internal harness, see VSM sub-section 8.2.22.
- Remove the internal lubrication pipe, see VSM sub-section 8.2.23.
- Remove the manual detent spring assembly, see VSM sub-section 8.2.25.
- Remove the internal dipstick stop, see VSM sub-section 8.2.24.
- Remove the valve body and accumulator assembly, see sub-section 1.7.3 (this manual).



- Note the internal harness runs for assembly purposes.
- Disconnect the internal harness plug from 'A' shift solenoid.
- Disconnect the internal harness plug from 'B' shift solenoid.
- Disconnect the internal harness plug from the temperature sensor.
- Disconnect the internal harness plug from the pulse width modulator (TCC solenoid).
- Disconnect the internal harness plug from the variable force motor and place aside.
- Release and remove 'A' shift solenoid to valve body securing screw.
- Invert valve body assembly.
- Release and remove accumulator block to valve body securing bolts.
- Remove accumulator block assembly from valve body.
- Remove and discard accumulator block to sandwich plate gasket.
- Remove sandwich plate from valve body.
- Remove and discard sandwich plate to valve body gasket.
- Clean all relevant parts and faces.
- Place valve body aside.
- Place new valve body – supplied with new valves, solenoids etc – to front.
- Fit new gasket to valve body.
- Fit sandwich plate to valve body.
- Fit two bolts to sandwich plate / valve body for alignment purposes, see Fig. 1.

Note: Select the close fitting bolt hole of the valve body and the elongated hole of the sandwich plate.

- Fit new accumulator block to sandwich plate gasket.
- Fit springs to accumulator block pistons.
- Fit and align accumulator block, pistons and springs assembly to valve body sandwich plate.
- Depress accumulator assembly against spring pressure.
- Fit and tighten accumulator block to valve body securing bolts.
- Remove the two bolts from sandwich plate / valve body (used for alignment purposes).
- Invert valve body assembly.
- Connect internal harness plug to variable force motor.
- Connect internal harness plug to pulse width modulator.
- Connect internal harness plug to temperature sensor.
- Connect internal harness plug to 'B' shift solenoid.
- Connect internal harness plug to 'A' shift solenoid.
- Refit valve body and accumulator assembly to transmission, see sub-section 1.7.3 (this manual); ensure that the nine checkballs are correctly located, see Figs. 2 and 3.

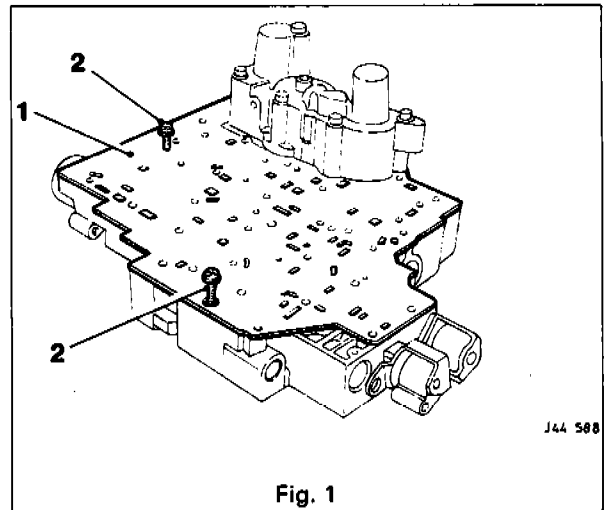

Fig. 1

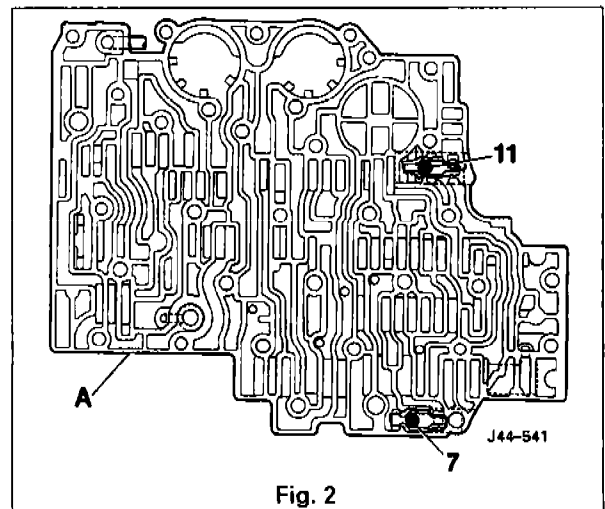

Fig. 2

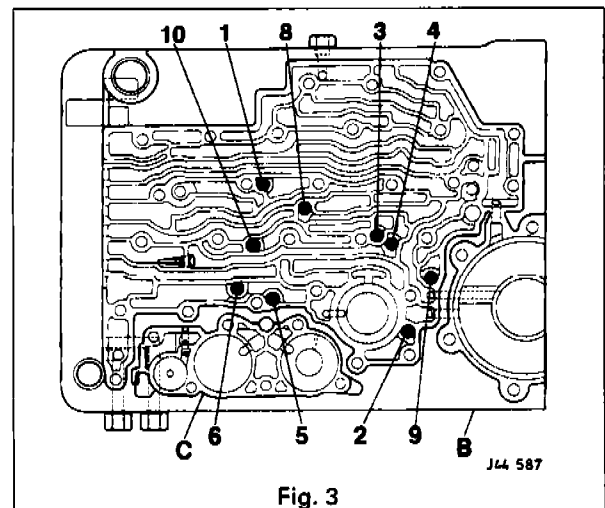

Fig. 3



- Refit internal dipstick stop, see VSM sub-section 8.2.24.
- Refit manual detent spring assembly, see VSM sub-section 8.2.25.
- Refit internal lubrication pipe, see VSM sub-section 8.2.23.
- Fit new internal harness multipin socket O-ring seal, see VSM sub-section 8.2.22.
- Refit multipin socket to main case and connect external harness, see VSM sub-section 8.2.22.
- Refit fluid filter, see VSM sub-section 8.2.21.
- Refit fluid pan, see VSM sub-section 8.2.17 (4.0 liter SC) and sub-section 8.2.18 (V12).
- Lower the vehicle on the ramp.
- Refill the transmission with fluid, see 8.2.16.
- Lower the hood.

**A**

- Accumulators, Description, 6**
- Active components for each ratio, Table, 10**

C

- Checkball valves, Description, 8**
- Converter limiting valve, Description, 7**
- Cooler circuit, 3**

F

- Fault diagnosis**
 - Electrical checks, 24
 - Engine tune, 24
 - Initial checks, 24
 - Road test, 24
 - Stall test, 24
 - Transmission fault codes, Listing, 25

Foreword, ii

Front servo assembly, Renew, 27

G

- Gear ranges, 1**
- General description**
 - Cooler circuit, 3
 - Gear ranges, 1
 - Lubrication circuit, 3
 - Transmission assembly cutaway illustration, 2

H

- Hydraulic circuit diagrams**
 - '2' – 2nd, 23
 - '3' – 3rd, 22
 - 'D' – drive, 1st, 15
 - 'D' – drive, 2nd, 16
 - 'D' – drive, 3rd, 17
 - 'D' – drive, 3rd to 2nd, 21
 - 'D' – drive, 4th lock-up, TCC on, 19
 - 'D' – drive, 4th to 3rd, 20
 - 'D' – drive, 4th, TCC off, 18
 - 'N' – neutral, 14
 - 'P' – park, 12
 - 'R' – reverse, 13
 - Key, 11

I

Input & output speed sensors, Description, 6

L

Lubrication circuit, 3

O

- Oil pump & internal valves**
 - Converter limiting valve, Description, 7
 - Pressure regulator valve train, Description, 7

- Reverse boost valve, Description, 7
- Torque converter clutch enable valve, Description, 7
- Torque converter clutch shift valve, Description, 7

P

- Planetary gear sets**
 - Description, 5
 - Illustration, 4
- Pressure regulator valve train, Description, 7**
- Pressure switch manifold, Description, 6**
- PWM solenoid, Description, 6**

R

- Rear servo assembly (V12 applications), Renew, 26**
- Reverse boost valve, Description, 7**

S

- Service data, iii**
- Service materials, iii**
- Service Operations**
 - Remove for access & refit, Valve body & accumulator, 28
 - Renew, Valve body assembly, 29
- Service operations, Renew**
 - Front servo assembly, 27
 - Rear servo assembly (V12 applications), 26
- Service tools & equipment, iii**
- Shift solenoids, Description, 6**

T

- Torque converter, Description, 5**
- Torque converter clutch, Description, 5**
- Torque converter clutch enable valve, Description, 7**
- Torque converter clutch shift valve, Description, 7**
- Torque signal compensatory valve, Description, 8**
- Torque tightening specifications, iii**
- Transmission assembly cutaway illustration, 2**



Transmission components

- Accumulators, Description, 6
- Input & output speed sensors, Description, 6
- Planetary gear sets
 - Description, 5
 - Illustration, 4
- Pressure switch manifold, Description, 6
- PWM solenoid, Description, 6
- Shift solenoids, Description, 6
- Torque converter, Description, 5
- Torque converter clutch, Description, 5
- Transmission control module, Description, 6
- Transmission temperature sensor, Description, 6
- Variable force solenoid / motor, Description, 6

Transmission control module, Description, 6

Transmission fault codes, Listing, 25

Transmission temperature sensor, Description, 6

V

Valve body & accumulator, Renew, 28

Valve body assembly, Renew, 29

Valve body valves

- Checkball valves, Description, 8
- Torque signal compensatory valve, Description, 8

Variable force solenoid / motor, Description, 6